

# INSTRUCTION MANUAL

Meade® Model 102ACHR/500

4" Achromatic Refracting Telescope



**Meade Instruments Corporation**

美國

## WARNING!

Never use the Meade Model 102ACHR/500 Telescope to look at the Sun! Observing the Sun, *even for the shortest fraction of a second*, will cause instant and irreversible damage to your eye as well as physical damage to the telescope itself. When observing with the telescope during the daytime, do not point the telescope even close to the Sun.

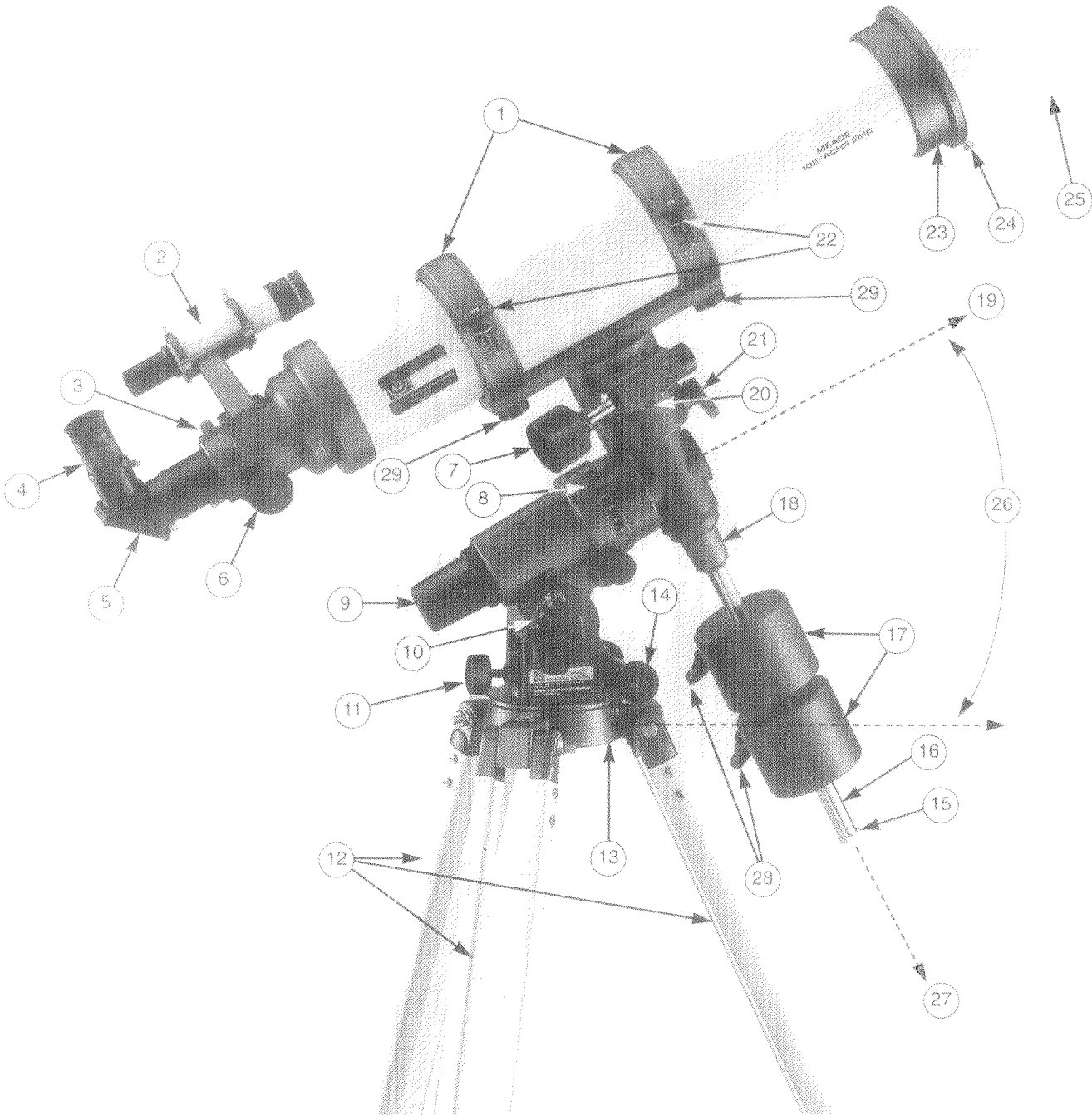

Fig. 1: The Meade Model 102ACHR/500 Refracting Telescope

Captions for Fig. 1

1. Cradle Rings
2. Viewfinder
3. Focuser Lock Knob
4. Eyepiece
5. Diagonal Prism
6. Focus Knob
7. Declination (Dec) Slow Motion Control
8. Right Ascension (R.A.) Setting Circle
9. Dust Cover for Optional #812 Polar Alignment Finder
10. Latitude Scale
11. Fine Latitude Adjustment Knob
12. Tripod Legs
13. Tripod Head
14. Fine Azimuth Adjustment Knob
15. Counterweight Safety Stop
16. Counterweight Rod
17. 7.5 lb (3.4 kg) Counterweights
18. Counterweight Cone
19. Polar Axis
20. Dec Setting Circle
21. Dec Lock Lever
22. Cradle Ring Knobs
23. Objective Lens Cell
24. Dew Shield Safety Screw
25. Dew Shield
26. Latitude Angle (Elevation Angle) of the Polar-Aligned Telescope
27. Declination Axis
28. Counterweight Lock Screws
29. Cradle Ring Lock Knobs

**CAUTION!**

The Meade Model 102ACHR/500 telescope is a serious astronomical instrument. Because of the significant weight of the telescope, children should not be allowed to play near the telescope at any time. Parents should use caution and common sense when allowing children to observe through the telescope.

**Contents**

**Model 102ACHR/500  
4" Achromatic Refractor**

Introduction . . . . .	4
Parts Listing and Assembly . . . . .	4
Preparing the LXD 500 Tripod . . . . .	4
Setting Up the tripod . . . . .	4
Attaching the Accessory Tray . . . . .	4
Varying the Tripod Height . . . . .	4
Collapsing the Tripod . . . . .	4
Assembly of the Equatorial Mount . . . . .	4
Attaching the Equatorial Head to the Tripod . . . . .	5
Attaching the Counterweights . . . . .	5
Slow Motion Control Knobs . . . . .	5
Mounting the Cradle Rings . . . . .	5
Mounting the Optical Tube Assembly . . . . .	6
Attaching the Diagonal Prism and Eyepiece . . . . .	6
Mounting the Viewfinder . . . . .	6
Balancing the Telescope . . . . .	6
First Observations . . . . .	7
Telescope Controls . . . . .	7
The Viewfinder . . . . .	7
Focusing the Viewfinder . . . . .	7
Alignment of the Viewfinder . . . . .	7
Using the Viewfinder . . . . .	8
Magnification . . . . .	8
Astronomical Observing . . . . .	8
Celestial Coordinates: Declination & Right Ascension . . . . .	8
Polar Alignment . . . . .	9
Polar Alignment Procedures . . . . .	9
Using a Polar Aligned Telescope . . . . .	10
Locating Astronomical Objects . . . . .	10
Precise Polar Alignment Procedures . . . . .	10
Setting Circles . . . . .	10
Observing Tips . . . . .	10
Terrestrial Observing . . . . .	11
Image Orientation . . . . .	11
Optional Accessories . . . . .	11
Telescope Maintenance and Servicing . . . . .	12
General Maintenance Guidelines . . . . .	12
Proper Storage and Transport of the Telescope . . . . .	13
Meade Customer Service . . . . .	13
Specifications . . . . .	14

**Technical Note:** The Model 102ACHR/500 may be supplied in either of two versions: with either the Meade LXD 500A Equatorial Mount (with aluminum gears) or the LXD 500B Equatorial Mount (with bronze gears). Set up and operation of the telescope are identical in either case.

© The name 'Meade' and the Meade logo are trademarks registered with the U.S. Patent Office and in principal countries throughout the world.

## MODEL 102ACHR/500 4" ACHROMATIC REFRACTOR: INTRODUCTION

The Meade Model 102ACHR/500 Telescope is ideally suited to the serious beginning or intermediate amateur astronomer or terrestrial observer. With its 2-element, 4" achromatic objective lens, observers can view craters and fault lines on the Moon; cloud features on the planet Jupiter and Jupiter's four largest moons; as well as the rings of Saturn and Saturn's largest moon, Titan. Beyond the Solar System, the Model 102ACHR/500 telescope permits detailed observations of nebulae, star clusters, galaxies, and other deep-space objects.

For optimal enjoyment of the Meade Model 102ACHR/500 telescope, please take a few minutes to read this manual thoroughly and become familiar with all of the instrument's astronomical and terrestrial observing capabilities.

## PARTS LISTING AND ASSEMBLY

When opening the two packing boxes for the first time, note carefully the following parts included with the Model 102ACHR/500 telescope:

### Box 1:

- Optical Tube Assembly, with cradle rings attached.
- Accessories, packed with the optical tube assembly:
  - Plössl (PL) 25mm eyepiece
  - #918A diagonal prism
  - 6 x 30mm viewfinder and bracket

### Box 2:

- LXD 500 Equatorial Mount, including:
  - Tripod
  - Equatorial head
  - Lock knob with twist bar (Fig. 4)
  - 2 washers (1 large and 1 small washer for lock knob with twist bar)
  - Counterweight rod with gray counterweight cone
  - 2 pcs. 7.5 lb (3.4 kg) counterweights
  - 2 slow motion control knobs
  - Accessory tray

### To assemble the telescope, follow these steps:

#### 1. Preparing the LXD 500 tripod

The LXD 500 tripod (Fig. 2) is shipped virtually completely assembled from the factory. Once set up, all that is required of an observer is to attach the accessory tray and adjust the tripod to the desired observing height.

##### a. Setting Up the Tripod:

Remove the tripod from the shipping box and stand the tripod vertically with the tripod feet down. Grasp two of the tripod legs and with the full weight of the tripod on the third leg, gently pull the legs apart to the fully open position (Fig. 2).

##### b. Attaching the Accessory Tray:

Remove the round accessory tray (4), Fig. 2, from the shipping box.

Unthread the black, star-shaped lock knob from the bottom of the tray.

Place the threaded rod on the underside of the accessory tray through the central hub of the extension strut. Rethread the lock knob onto the accessory tray.

##### c. Varying the Tripod Height:

Loosen the black, star-shaped height adjustment knob (5), Fig. 2, at the base of each tripod leg.

Slide the three inner tripod leg sections out to the desired height.

Firmly tighten (but do not overtighten) the three height adjustment knobs (5), Fig. 2.

##### d. Collapsing the Tripod:

Remove the accessory tray (4), Fig. 2. Grasp the tripod head (2), Fig. 2, with one hand. With the other hand, pull directly up on the central hub of the extension strut, where the accessory tray (4), Fig. 2, was attached. This action will cause the tripod legs to move inward to a collapsed position.

#### Important Notes on the LXD 500 Tripod:

- Remove the accessory tray before attempting to collapse the tripod.
- If the tripod does not extend or collapse easily, do not force the tripod legs in or out. By following the above instructions, the tripod will function properly. Forcing the tripod into an incorrect position may damage the extension strut system.
- Do not overtighten the three star-shaped height adjustment knobs on the tripod legs. "Firm feel" tightening is sufficient.

#### 2. Assembly of the Equatorial Mount

All the parts required for the Equatorial Mount can be found (with the tripod) in the LXD 500 Mount shipping box. The Optical Tube Assembly (OTA) is shipped in a separate box. To assemble the mount, follow these instructions:

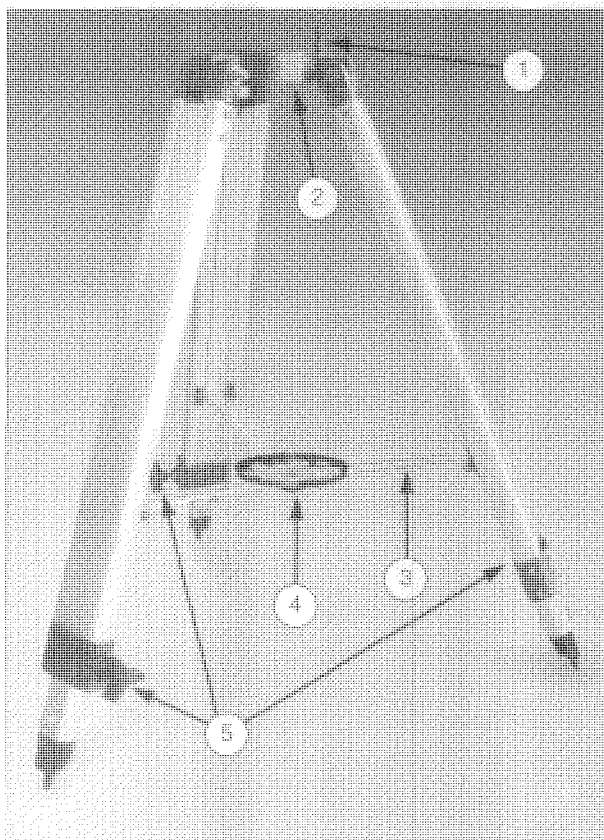
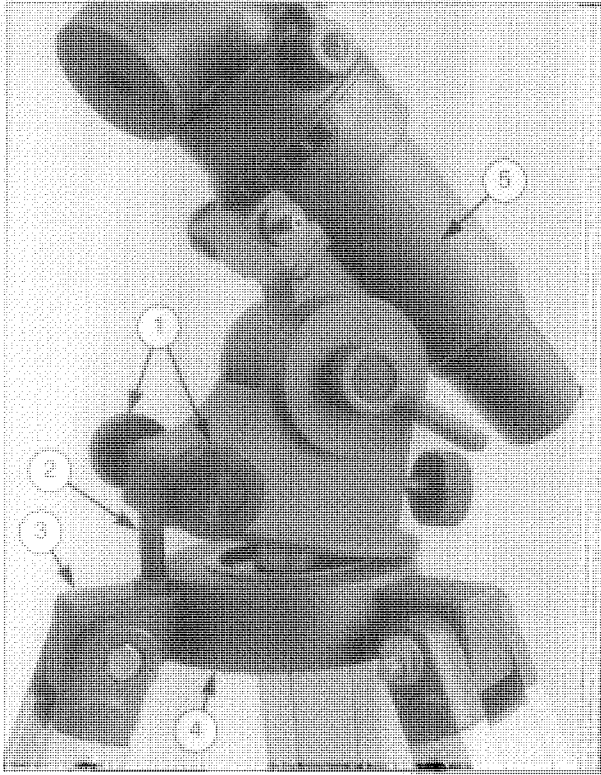

Fig. 2 LXD 500 Tripod. (1) Azimuth Tangent Arm; (2) Tripod Head; (3) Extension Strut; (4) Accessory Tray; (5) Height Adjustment Knob.

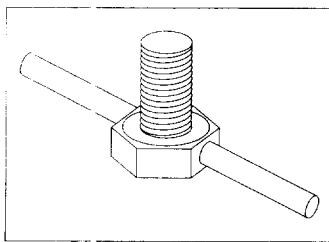

**Fig. 3:** Attaching the Equatorial Head to Tripod. (1) Fine Azimuth Adjustment Knobs; (2) Azimuth Tangent Arm; (3) North Facing Tripod Leg; (4) Tripod Head; (5) Equatorial Head.

**a. Attaching the Equatorial Head to the Tripod:**

On the Equatorial Head (5), Fig. 3, loosen the two Fine Azimuth Adjustment Knobs (1), Fig. 3, to create a space between the two knobs (as seen from the underside of the Equatorial Head). The Azimuth Tangent Arm (2), Fig. 3, fits between these two threaded knobs.

Unthread and remove the lock knob with twist bar, Fig. 4, and two washers from the base of the Equatorial Head (5),



**Fig. 4:** Lock Knob with Twist Bar.

Fig. 3. Place the Equatorial Head on the Tripod Head (4), Fig. 3, aligning it so that the Azimuth Tangent Arm (2), Fig. 3, slips between the two Fine Azimuth Adjustment Knobs (1), Fig. 3.

With the Equatorial Head (5), Fig. 3, sitting flat on the Tripod Head (4), Fig. 3, place the small washer, then the large washer over the threads of the lock knob with twist bar, Fig. 4, and, from the underside of the Tripod Head, thread the lock knob with twist bar (and washers) through the Tripod Head and into the base of the Equatorial Head. Tighten firmly but do not overtighten.

Simultaneously tighten both of the Fine Azimuth Adjustment Knobs (1), Fig. 3. Each knob will press against the Azimuth Tangent Arm (2), Fig. 3. Do not overtighten.

**b. Attaching the Counterweights:**

On the counterweight rod (3), Fig. 5, confirm that the gray counterweight cone (2), Fig. 5, is threaded onto the rod as far as possible. Then, thread the counterweight rod, with the counterweight cone in place, into the bottom of the declination housing (1), Fig. 5. When the counterweight

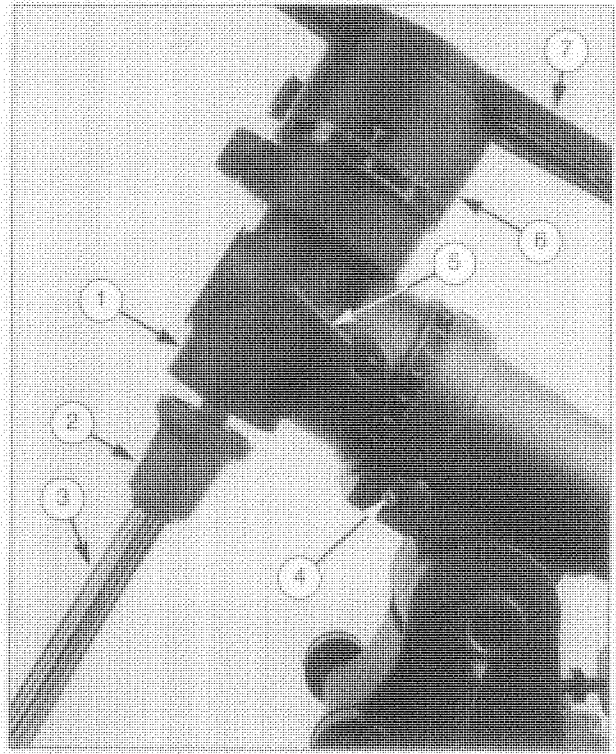

**Fig. 5:** Installing Counterweight Rod. (1) Declination Housing; (2) Counterweight Cone; (3) Counterweight Rod; (4) R.A. Slow Motion Control Shaft; (5) R.A. Lock Lever; (6) Dec Slow-Motion Control Shaft (on opposite side); (7) Saddle Plate.

rod is threaded in as far as possible, additionally secure the rod by turning the gray counterweight cone (2), Fig. 5, clockwise until tight.

At the end of the counterweight rod (3), Fig. 5, unscrew the counterweight safety stop (15), Fig. 1. Slide each counterweight onto the rod and lock in place by tightening its black counterweight lock screw (28), Fig. 1. As soon as the second counterweight is secure, replace the counterweight safety stop. **Be certain that the counterweight safety stop is always securely in place.**

**c. Slow Motion Control Knobs:**

There are two identical slow motion control knobs. See (2) and (4), Fig. 7. Attach one of these knobs to the R.A. Slow Motion Control Shaft (4), Fig. 5, by aligning the knob so that its knurled thumb screw will slide directly over the flat area on the R.A. Slow Motion Control Shaft. Tighten the knurled thumb screw to a firm feel. Do not overtighten.

Attach the second knob to the Dec Slow Motion Control Shaft (6), Fig. 5, by aligning the knob so that its knurled thumb screw will slide directly over the flat area on the Dec Slow Motion Control Shaft. Tighten the knurled thumb screw to a firm feel. Do not overtighten.

**d. Mounting the Cradle Rings:**

The Optical Tube Assembly (OTA) is shipped from the factory with the cradle rings (1), Fig. 1, secure around the tube. To remove the cradle rings from the OTA, loosen each cradle ring knob (22), Fig. 1. The cradle rings are hinged so they can be opened by lifting the top portion of the ring.

Unthread and remove the cradle ring lock knob (29), Fig. 1, found at the base of each cradle ring (1), Fig. 1. Align the base of each cradle ring with a mounting hole on the saddle plate (7), Fig. 5, and thread a lock knob up through the saddle plate into each cradle ring. Tighten to a firm feel.

Note: The cradle rings may be attached with the cradle ring knobs on either the left or right side of the equatorial head, as long as both hinges open in the same direction.

**e. Mounting the Optical Tube Assembly:**

Before placing the OTA in the cradle ring assembly, confirm that the counterweights are attached to the mount and the R.A. lock lever (3), Fig. 7, and the Dec lock lever (1), Fig. 7, are firmly locked by rotating each lever clockwise until it stops.

With both cradle rings open, place the OTA into the cradle ring assembly. With one hand holding the OTA in place, close the cradle rings. Tighten the two cradle ring knobs to a firm feel. Do not overtighten.

Located at the end of the OTA is the Dew Shield (25), Fig. 1, which can be removed when cleaning the objective lens (See General Maintenance Guidelines, page 12.) Care should be taken when replacing the Dew Shield to tighten the Dew Shield Safety Screw (24), Fig. 1. Tightening of the safety screw will prevent accidental dislodgment of the Dew Shield during an observing session

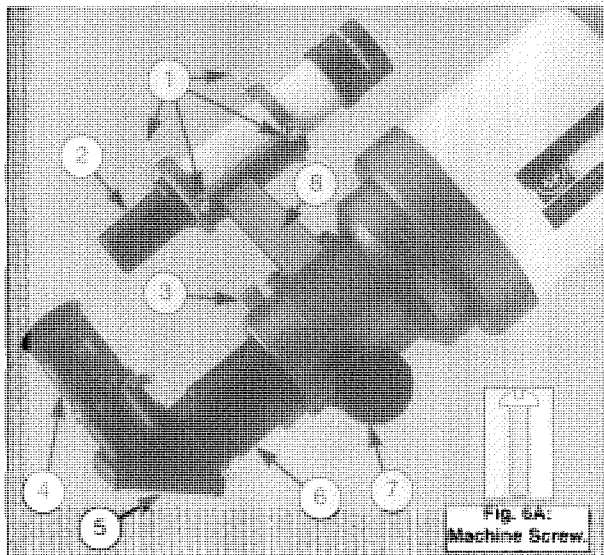

**Fig. 6:** Attaching the Diagonal Prism and Eyepiece. (1) Alignment Screws; (2) Viewfinder; (3) Focus Lock Knob; (4) Eyepiece; (5) Diagonal Prism; (6) Focuser Drawtube; (7) Focus Knob; (8) Viewfinder Mount.

**f. Attaching the Diagonal Prism and Eyepiece:**

Slide the diagonal prism (5), Fig. 6, directly into the focuser drawtube (6) Fig. 6, of the telescope and lock in place by turning its thumbscrew clockwise until tight (firm-feel only).

Insert the provided PL 25mm eyepiece (4), Fig. 6, into the diagonal prism and lock in place by tightening the thumbscrew. **Do not overtighten the thumbscrews.**

Note For astronomical observations, the diagonal prism generally provides a comfortable right-angle viewing position. Alternately, an eyepiece may be inserted directly into the rear cell for straight-through observations. With the diagonal prism in place, images will be right-side-up but reversed left-for-right. With the eyepiece inserted directly into the rear cell (straight through), images will be upside-down. For astronomical purposes, the image orientation is usually of no importance. For terrestrial observations, where a fully corrected image is highly desirable, the optional Meade #928 45° Erect-Image Diagonal Prism should be ordered separately. (See Optional Accessories, page 12.)

**g. Mounting the Viewfinder:**

The viewfinder, bracket and mounting hardware are shipped in the box with the optical tube assembly.

Between the focus lock knob (3), Fig. 6, and the optical tube, locate the four machine screws, Fig 6A, threaded into holes on the flat, viewfinder mounting area.

Remove the four machine screws. Align the two holes and the two open slots on the base of the viewfinder mount (8), Fig. 6, with the threaded holes on the viewfinder mounting area. Thread the four screws through the viewfinder mount into the telescope. Tighten to a firm feel, but do not overtighten. Alignment of the viewfinder is discussed later in this manual.

**BALANCING THE TELESCOPE**

The telescope must be balanced around both axes. With an improperly balanced telescope, objects may become difficult to find or, once found, may be easily lost. To balance the telescope:

1. Loosen the R.A. lock lever (3), Fig. 7, by rotating the lever counterclockwise until it stops. The Optical Tube Assembly now rotates freely about the Polar Axis (19), Fig. 1. Rotate the telescope so that the counterweight rod is parallel to the ground (horizontal).
2. Loosen the counterweight lock screws (28), Fig. 1, and slide the counterweights along the rod until the telescope remains in one position without tending to drift in either direction. Re-tighten the counterweight lock screws and the R.A. lock lever.
3. Loosen the Dec lock lever (1), Fig. 7, by rotating the lever counterclockwise until it stops. The Optical Tube Assembly now rotates freely about the Declination Axis (27), Fig. 1. Rotate the optical tube assembly so that the tube is parallel to the ground (horizontal).
4. Slightly loosen the two cradle ring knobs (22), Fig. 1.
5. Slide the tube back and forth within the cradle rings until the telescope is in balance about the Declination Axis. Tighten the cradle ring knobs and the Dec lock lever when balanced.

With the telescope properly balanced, it is possible to place the optical tube in any position without drifting. Rebalancing may be necessary with the addition of any optional accessories.

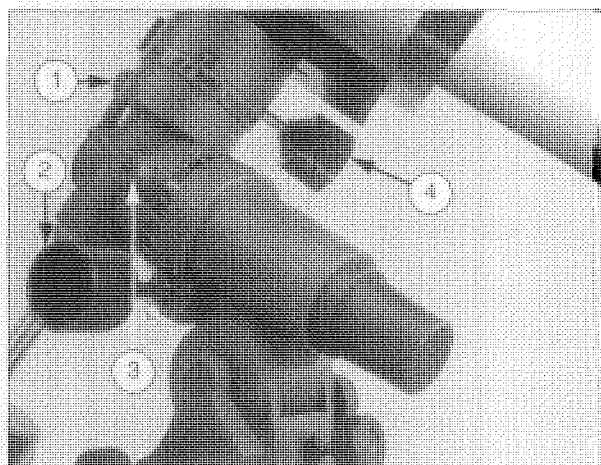

**Fig. 7:** Telescope Controls. (1) Dec Lock Lever; (2) R.A. Slow-Motion Control; (3) R.A. Lock Lever; (4) Dec Slow-Motion Control.

## FIRST OBSERVATIONS

Remove the dust cover from the objective lens by gently twisting the cover and pulling it away from the objective lens.

### Telescope Controls

An important array of controls facilitates operation of the Model 102ACHR/500 telescope. It is best to become familiar with all of these controls before attempting observations through the telescope.

**Focus Knobs (7)**, Fig. 6: Turning these knobs moves the eyepiece closer to or farther away from the objective lens, thereby changing the focus. The telescope can be focused on objects from a distance of about 50 feet to infinity.

**Focus Lock Knob (3)**, Fig. 6: The focus lock knob is designed to prevent the focuser drawtube (6), Fig. 6, from moving when heavy accessories (e.g., a camera body) are attached to the focuser assembly. For normal observing, with an eyepiece and diagonal mirror, it is not necessary to utilize the lock knob.

**Dec Lock Lever (1)**, Fig. 7: Locking and unlocking the Declination movement of the optical tube is accomplished by moving the Dec lock lever clockwise until it stops for the fully locked position, or by moving the Dec lock lever counterclockwise to the fully unlocked position.

**Dec Slow-Motion Control (4)**, Fig. 7: With the Dec lock lever in the fully locked position, the Dec Slow-Motion Control may be used for fine motions of the telescope in Declination. (The meaning of "Dec," or Declination, is explained later in the manual.)

**R.A. Lock Lever (3)**, Fig. 7: Locking and unlocking the Right Ascension movement is accomplished by rotating the R.A. lock lever clockwise until it stops for the fully locked position and counterclockwise for the fully unlocked position.

**R.A. Slow-Motion Control (2)**, Fig. 7: With the R.A. lock lever fully locked, the R.A. Slow-Motion Control permits manual slow-motion of the telescope in Right Ascension. (The meaning of "R.A.," or Right Ascension, is explained later in the manual.)

After becoming familiar with the telescope's controls, make your first observations of a simple land object — a telephone pole or building, perhaps, several hundred yards in the distance. Keep in mind that the viewfinder has not been aligned, so it will be necessary to sight along the optical tube to "aim" the telescope at the object. With the PL 25mm eyepiece in place, unlock the R.A. and Dec lock levers. The telescope now turns freely on both axes, permitting the location of objects in the telescope. With an object roughly centered in the telescopic field, as viewed through the eyepiece, retighten the R.A. and Dec lock levers. While looking through the eyepiece, turn the focus knob clockwise or counterclockwise until the object is in focus.

*Note: With the eyepiece inserted directly into the rear cell of the telescope, without using the diagonal prism, the image through the eyepiece will be inverted and reversed left-for-right. The inverted image is a result of the optical structure of the telescope and is normal for astronomical telescopes. If the diagonal prism is inserted into the telescope first, then the eyepiece, the image appears right-side-up, but still reversed left-for-right.*

Once the selected object is in focus, with the R.A. lock lever and Dec lock lever LOCKED, use the R.A. Slow-Motion Control and the Dec Slow-Motion Control to center the object in the field of view.

## THE VIEWFINDER

The Model 102ACHR/500 telescope, as with almost all astronomical telescopes, presents a fairly narrow field of view to

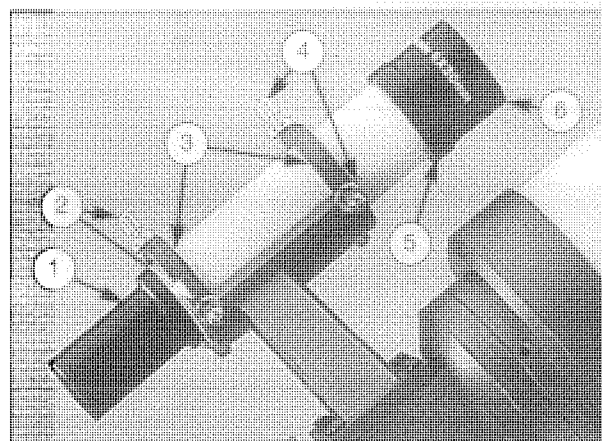

Fig. 8: Viewfinder. (1) Viewfinder Eyepiece; (2) Rear Alignment Screws; (3) Mounting Bracket; (4) Front Alignment Screws; (5) Focus Lock Ring; (6) Objective Lens Cell.

the observer. As a result, it is sometimes difficult to locate and center objects in the telescope. The viewfinder, by contrast, is a low-power, wide-field sighting scope with crosshairs that enable the easy centering of objects in the main telescope's field of view. Standard equipment with the Model 102ACHR/500 telescope is a viewfinder of 6-power and 30mm aperture, called a "6 x 30mm viewfinder."

### 1. Focusing the Viewfinder

The viewfinder has been factory prefocused to objects located at infinity. Individual eye variations, however, may require that the viewfinder be refocused to your eye. Looking through the viewfinder, point the telescope at a distant object; if the viewfinder image is not sufficiently in focus for your eye, it may be refocused as follows:

- Remove the viewfinder from its mounting bracket (3), Fig. 8, by slightly unthreading the six alignment screws (2) and (4), Fig. 8, until the viewfinder can slip out easily.
- Loosen the focus lock ring (5), Fig. 8, thereby enabling rotation of the viewfinder's objective lens cell (6), Fig. 8. While looking at a distant object through the viewfinder, rotate the objective lens cell clockwise or counterclockwise until sharp focus is achieved.
- Tighten the focus lock ring (5), Fig. 8, to lock the focus in place.
- Replace the viewfinder into its bracket (3), Fig. 8, on the main telescope.

*Note: No focusing is possible (or required) from the eyepiece end of the viewfinder.*

### 2. Alignment of the Viewfinder

In order for the viewfinder to be useful, it must first be aligned with the main telescope, so that both the viewfinder and the main telescope are pointing at precisely the same place. To align the viewfinder, follow this procedure:

- The viewfinder bracket includes six alignment screws. Turn the three rear alignment screws (2), Fig. 8, roughly centering the viewfinder within its bracket (as viewed from the eyepiece-end of the telescope). When centered, tighten the knurled lock nut on each of the three rear alignment screws until the lock nuts are flush against the bracket ring.
- Using the standard equipment PL 25mm eyepiece, point the main telescope at some easy-to-locate, well-defined,

but distant, land object, such as the top of a telephone pole. Center the object precisely in the main telescope's field and lock the R.A. lock lever and Dec lock lever so that the telescope does not move away from the object.

- c. While looking through the viewfinder, turn one or more of the three front viewfinder alignment screws (4), Fig. 8, until the crosshairs of the viewfinder point at precisely the same position as the main telescope. Tighten the knurled lock nut on each of the front alignment screws until the lock nuts are flush against the bracket ring.

The viewfinder is now aligned with the main telescope. Unless the alignment screws are disturbed, the viewfinder will remain aligned indefinitely.

### 3. Using the Viewfinder

Now, to locate any object, terrestrial or astronomical, first center the object on the crosshairs of the viewfinder; the object will then be centered in the field of the main telescope.

*Note: If higher observing magnifications are desired, first locate, center, and focus the object using a low-power eyepiece (e.g., the PL 25mm eyepiece). Objects are easier to locate and center at low powers; higher powers may then be employed by changing eyepieces.*

## MAGNIFICATION

The magnification, or power, at which a telescope is operating is determined by two factors: the focal length of the eyepiece employed and the focal length of the telescope. The Model 102ACHR/500 telescope is supplied with one eyepiece as standard equipment. The focal length of the eyepiece, 25mm, is printed on its side.

Telescope focal length is, roughly speaking, the distance that light travels inside the telescope before reaching a focus. The focal length of the Model 102ACHR/500 telescope is 920mm.

On a given telescope, different eyepiece focal lengths are used to achieve different magnifications, from low to high. Optional eyepieces and the Series 4000 #140 2x Barlow Lens are available for powers from a range of about 25x to 400x, depending on the focal length of the telescope and eyepiece (see OPTIONAL ACCESSORIES, page 11).

To calculate the magnification (or power) obtained with a given eyepiece, use this formula:

$$\text{Power} = \frac{\text{Telescope Focal Length}}{\text{Eyepiece Focal Length}}$$

Example: Using the PL 25mm eyepiece supplied with the Model 102ACHR/500 telescope, the power is:

$$\text{Power} = \frac{920\text{mm}}{25\text{mm}} = 37\text{x}$$

The most common mistake of the beginning observer is to "overpower" the telescope and use high magnifications which the telescope's aperture and typical atmospheric conditions cannot reasonably support. Keep in mind that a smaller but bright and well-resolved image is far superior to a larger but dim and poorly resolved one. Powers above about 200x should be employed only under the steadiest atmospheric conditions.

Most observers will want to have 3 or 4 eyepieces and perhaps the Series 4000 #140 2x Barlow Lens to achieve the full range of reasonable magnifications. See OPTIONAL ACCESSORIES, page 11, for further details.

## ASTRONOMICAL OBSERVING

Understanding how and where to locate celestial objects, and how those objects move across the sky is fundamental to enjoying the hobby of astronomy. This section provides a basic introduction to the terminology associated with astronomy, and includes instructions for finding and tracking celestial objects.

### Celestial Coordinates: Declination and Right Ascension

Celestial objects are mapped according to a coordinate system on the Celestial Sphere, the imaginary sphere on which all stars appear to be placed. This celestial object mapping system is analogous to the Earth-based coordinate system of latitude and longitude.

The poles of the celestial coordinate system are defined as those two points where the Earth's rotational axis, if extended to infinity, north and south, intersect the celestial sphere. Thus, the North Celestial Pole is that point in the sky where an extension of the Earth's axis through the North Pole intersects the celestial sphere. This point in the sky is located near the North Star, Polaris. The faint star Sigma Octans lies near the South Celestial Pole, where the extension of Earth's axis through the South Pole intersects the celestial sphere.

In mapping the surface of the Earth, lines of longitude are drawn between the North and South Poles. Similarly, lines of latitude are drawn in an east-west direction, parallel to the Earth's Equator. The Celestial Equator is a projection of the Earth's Equator onto the celestial sphere.

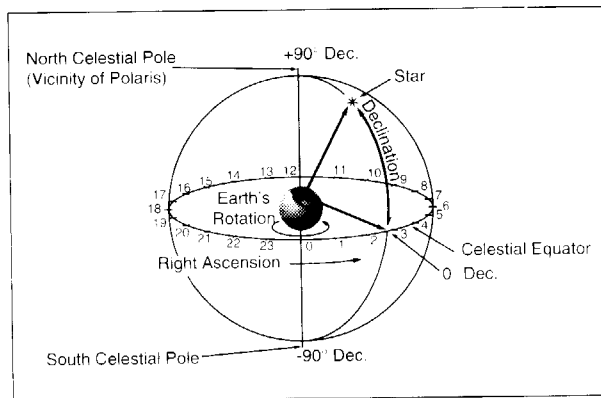

Fig. 9: The Celestial Sphere.

In mapping the celestial sphere, just as on the surface of the Earth, imaginary lines have been drawn to form a coordinate grid. Thus, object positions on the Earth's surface are specified by their latitude and longitude. For example, you could locate Los Angeles, California, by its latitude (34°) and longitude (118°); similarly, you could locate the constellation Ursa Major by its position on the celestial sphere:

R.A.: 11hr; Dec: +50°.

The celestial analog to Earth latitude is called Declination, or "Dec", and is measured in degrees, minutes and seconds (e.g., 15° 27' 33"). Declination north of the celestial equator is indicated with a "+" sign in front of the measurement (e.g., the Declination of the North Celestial Pole is +90°), with Declination south of the celestial equator indicated with a "-" sign (e.g., the Declination of the South Celestial Pole is -90°) (Fig. 9). Any point on the celestial equator itself (which, for example, passes through the constellations Orion, Virgo and Aquarius) is specified as having a Declination of zero, shown as 0° 0' 0".

The celestial analog to Earth longitude is called "Right Ascension", or "R.A.," and is measured in time on the 24 hour "clock" and shown in hours ("hr"), minutes ("min") and seconds ("sec") from an arbitrarily defined "zero" line of Right Ascension passing through the constellation Pegasus. Right Ascension coordinates range from 0hr 0min 0sec to 23hr 59min 59sec. Thus there are 24 primary lines of R.A., located at 15 degree intervals along the celestial equator. Objects located further and further east of the prime Right Ascension grid line (0hr 0min 0sec) carry increasing R.A. coordinates.

All celestial objects are specified in position by their celestial coordinates of Right Ascension and Declination. The telescope's Dec and R.A. setting circles (1) and (3), Fig. 10, may be dialed to the coordinates of a specific celestial object, which may then be located without a visual search. However, before making use of the telescope's setting circles to locate celestial objects, your telescope must first be polar aligned.

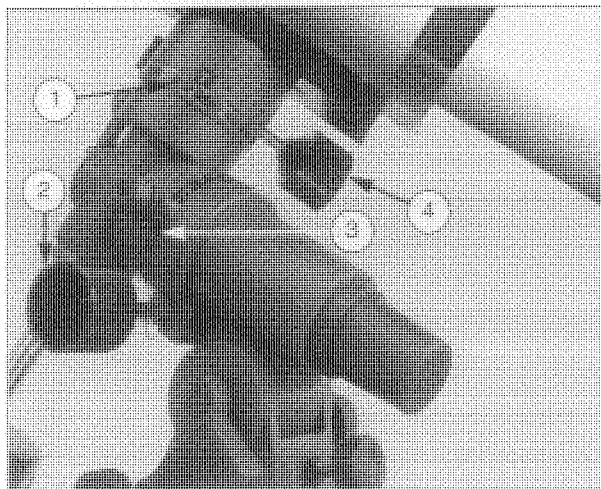

**Fig. 10:** R.A. and Dec Controls. (1) Dec Setting Circle; (2) R.A. Slow-Motion Control; (3) R.A. Setting Circle; (4) Dec Slow-Motion Control.

### Polar Alignment

Celestial objects are essentially fixed on the Celestial Sphere. However, they appear to move across the sky in an arc as the Earth rotates on its axis, with a complete rotation of the Earth occurring once in every 24 hour period. This apparent motion is not obvious to the unaided eye, but, when viewed through a telescope, this motion is rapid indeed. Objects centered in the telescope move entirely out of the field of view in 15 to 60 seconds, depending upon the magnification employed.

During the 24 hour period of the Earth's rotation, stars make one complete revolution about the Celestial Pole, making concentric circles with the Celestial Pole at the center. **By lining up the telescope's polar axis (19), Fig. 1, with the North Celestial Pole** (or South Celestial Pole if observing from the Earth's southern hemisphere), **celestial objects may be followed (tracked) by moving the telescope about only one axis, the polar axis.**

In addition, by polar aligning the telescope, the telescope's Dec and R.A. setting circles (1) and (3), Fig. 10, may be used to locate faint celestial objects directly from their catalogued coordinates.

### Polar Alignment Procedures:

Polar alignment consists of the following two operations:

1. Pick up the entire telescope-and-tripod and orient the tripod so that the leg directly beneath the counterweights (the leg marked "N") points due north.

For observers in the southern hemisphere, pick up the entire telescope-and-tripod and orient the tripod so that the leg directly beneath the counterweights (the leg marked "N") points due south.

2. Determine the latitude of your observing location by checking a road map or atlas. Then, adjust the latitude of the telescope-and-tripod to indicate the latitude of your observing location by turning the fine latitude adjustment knob (3), Fig. 11, clockwise or counterclockwise until the latitude pointer (1), Fig. 11, indicates the correct latitude on the latitude scale (6), Fig. 11.

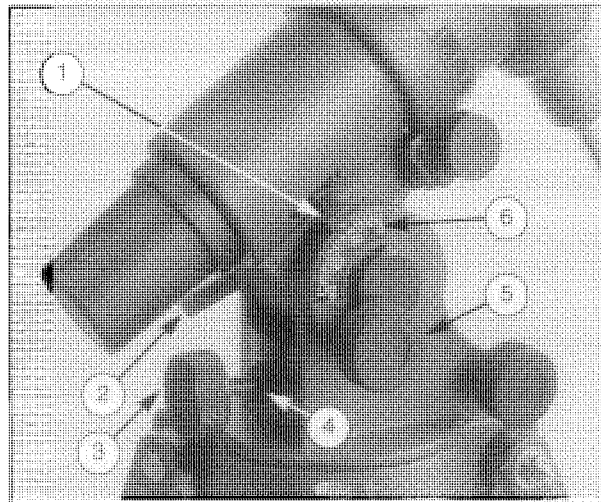

**Fig. 11:** Latitude Controls. (1) Latitude Pointer; (2) Latitude Lock Lever (opposite side); (3) Fine Latitude Adjustment Knob; (4) Lock Nut; (5) Latitude Lock Knob; (6) Latitude Scale.

It may be necessary to loosen the lock nut (4), Fig. 11, to allow enough movement of the mount to achieve the desired latitude. When the desired latitude has been achieved, tighten the lock nut until the nut is flush against the mount.

Step (1), above, is equivalent to pointing the telescope's polar axis (19), Fig. 1, due north (or due south for observers in the southern hemisphere). Step (2) is equivalent to making the telescope's latitude angle (26), Fig. 1, equal to the latitude angle of your observing location.

With (1) and (2) accomplished, the telescope is sufficiently well polar aligned for most visual observing applications.

For the majority of telescope applications, this procedure is entirely satisfactory. For those interested in astrophotography, or those interested in utilizing the telescope's setting circles to locate faint objects, a more precise polar alignment is necessary, requiring the optional #812 Polar Alignment Finder (see OPTIONAL ACCESSORIES, page 11).

*Note:* The Fine Azimuth Adjustment Knobs (14), Fig. 1, are generally only utilized during the precise polar alignment procedure described in the instructions accompanying the #812 Polar Alignment Finder.

Locating North by using Polaris, the North Star, is adequate for the purposes discussed above. Polaris can be found in relation to the Big Dipper by projecting a line from the so-called "pointer stars" of the Big Dipper (see Fig. 12). For southern hemisphere alignment, locate south by using the faint star Sigma Octans (the South Star).

- Avoid setting up the telescope inside a room and observing through an open window (or, worse, a closed window!) In such a case, air currents caused by differences in indoor/outdoor temperatures make quality astronomical optical performance impossible.

*Note: A practical exception to the above rule is the case where the telescope is, for example, set up in a living room or den for observing an outdoor terrestrial scene or view through a closed window. At low powers (up to about 60x) the telescope will perform reasonably well in this application, but the observer should understand clearly that optical performance under these conditions cannot approach the performance that will be realized if the telescope were instead set up outside.*

- As discussed above, avoid "overpowering" the telescope. If the terrestrial or astronomical image becomes fuzzy at high powers, drop down to a lower power. Image degradation at high powers is not due to any fault of the telescope but is caused by heat waves and turbulence in the earth's atmosphere. Astronomical observations at high powers (i.e., above about 200x) should be undertaken only when the atmosphere is very steady, as confirmed by an absence of "twinkling" in star images.
- Try not to touch the eyepiece when observing through the telescope. Vibrations in your hand are immediately transferred to the telescopic image.
- If an observer wears eyeglasses and does not suffer from astigmatism, he or she should take off the glasses when using the telescope; the telescope's magnification compensates for near- or farsightedness. Observers with astigmatism should, however, wear their glasses, since the telescope cannot compensate for this eye defect.
- Allow your eyes to become "dark adapted" before attempting serious astronomical observations through the telescope. Night adaptation normally requires about 10 to 15 minutes.
- As you use your telescope more and more for astronomical observing, you will find that you are seeing finer and finer detail — on the surface of Jupiter, for example. Observing through a fine optical instrument is, to some degree, an acquired skill. Celestial observing becomes increasingly rewarding as your eye becomes better trained in the detection of subtle variations of color, contrast, and resolution.

## TERRESTRIAL OBSERVING

Although principally designed for astronomical observing, the Model 102ACHR/500 telescope makes an excellent terrestrial observing tool. The telescope's controls are utilized in the same manner as for astronomical applications, but there are differences when locating and observing terrestrial subjects due to image orientation through the telescope.

### Image Orientation

The viewfinder presents an inverted image which appears upside-down and reversed left-for-right. With the standard-equipment diagonal prism and PL 25mm eyepiece in place in the main telescope, terrestrial images appear right-side-up, but reversed left-for-right. This orientation is usually acceptable for

terrestrial observing, except in the case of reading a distant sign or automobile license plate, for example.

Terrestrial image orientation can be fully corrected with the optional Meade #928 45° Erect-Image Diagonal Prism (see OPTIONAL ACCESSORIES, below).

## OPTIONAL ACCESSORIES

A wide assortment of professional Meade accessories is available for the Model 102ACHR/500 telescope. The premium quality of these accessories is well-suited to the quality of the instrument itself.

### Eyepieces

Meade Series 4000 Super Plössl (SP), Super Wide Angle (SWA), and Ultra Wide Angle (UWA) Eyepieces, in the standard American-size (1.25") barrel diameter, permit a range of magnifying powers with the telescope. Powers obtained with each eyepiece are as follows:

Eyepiece	Power
SP 6.4mm	144x
SP 9.7mm	95x
SP 12.4mm	74x
SP 15mm	61x
SP 20mm	46x
SP 26mm	35x
SP 32mm	29x
SP 40mm	23x
SWA 13.8mm	67x
SWA 18mm	51x
SWA 24.5mm	38x
UWA 4.7mm	196x
UWA 6.7mm	137x

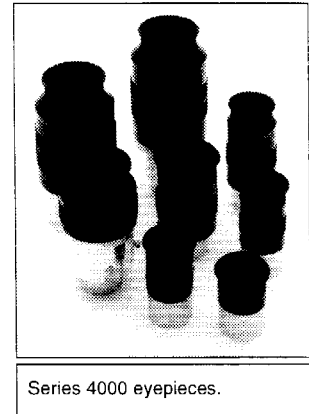

Meade Super Plössl and Super Wide Angle Eyepieces are ideal for general-purpose astronomical or terrestrial observing. The typical Model 102ACHR/500 user may wish to add 2 or 3 of these eyepieces to his or her telescope. An introductory selection might include the SP 9.7mm and SP 15mm.

The more advanced observer will perhaps select the SP 9.7mm, SP 12.4mm, and SWA 18mm. The Super Wide Angle Eyepiece series yields extremely wide fields of view, perfect for the examination of star fields, diffuse nebulae, or for terrestrial applications.

Under very steady seeing conditions Meade UWA 4.7mm and 6.7mm eyepieces present the widest fields of view obtainable at high powers and are excellent eyepieces for the Moon and planets.

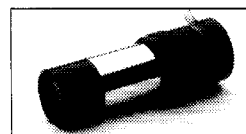

### #140 2x Barlow Lens

An amplifying lens, the Series 4000 #140 2x Barlow doubles the power of any eyepiece with which it is used. Insert the #140 into the

telescope's eyepiece-holder first, followed by the diagonal prism and eyepiece.

*Example:* For the Model 102ACHR/500, the standard equipment PL 25mm eyepiece yields a power of 37x; when used in conjunction with the Series 4000 #140 2x Barlow Lens, this eyepiece yields 74x.

### #812 Polar Alignment Finder

The LXD 500 equatorial mount has a provision in its polar axis for the addition of the #812 Polar Alignment Finder. This borescope device facilitates quick, precise polar alignment of the telescope. An internal reticle contains an etched clock-like scale. A separate Polar Reference Circle shows the correct position of the North Star on the Finder's reticle scale at any time and day of the year.



object in the field of view without manual adjustments in R.A. Add the #1705 Declination Motor to the #1701 for full dual-axis drive capabilities.

### #1702 Dual-Axis Drive System

Attaching the #1702 Dual-Axis Drive System to the LXD 500 Equatorial Mount provides quartz-controlled sidereal-rate tracking in R.A., plus full dual-axis drive capability at any of four photo-guide or microslew speeds: 2x, 8x, 16x, or 32x.

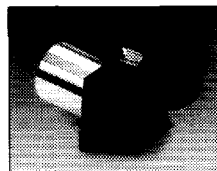

### #928 45° Erect-Image Diagonal Prism

Images through the diagonal mirror appear right-side-up, but reversed left for right. For terrestrial viewing, when correct image orientation is desired,

insert the #928 45° Erect-Image Diagonal Prism into the eyepiece holder of the 102ACHR/500 telescope, followed by an eyepiece. Use of the #928 results in a correctly oriented image at a convenient 45° angle.

### #1705 Declination Motor

The #1701 Single-Axis Drive System becomes a complete, fully functioning dual-axis drive system with the addition of the #1705 Declination Motor.

### Meade General Catalog

For your free copy of the Meade General Catalog write, call, or fax Meade Instruments:

**Meade Instruments Corporation**  
**16542 Millikan Avenue**  
**Irvine, CA 92606**  
**Phone: (714) 451-1450; Fax: (714) 451-1460**

### Epoch 2000sk Sky Software

Epoch 2000sk is the most powerful, most realistic sky software ever made available, allowing users to click on any one of 281,000 database objects displayed on a starfield to see the object's name, coordinates, magnitude, object type and description. Other features allow a user to zoom-in on telescope fields smaller than one arc second, locate planets to a precision of 0.1 arc seconds, print professional-quality star charts in either black and white or color and much more.



## TELESCOPE MAINTENANCE AND SERVICING

The Model 102ACHR/500 is a precision optical instrument designed to yield a lifetime of rewarding applications. Given the care and respect due any precision instrument, the Model 102ACHR/500 rarely requires servicing.

### General Maintenance Guidelines

1. Avoid cleaning the telescope's optics: a little dust on the front surface of the telescope's lens causes virtually no degradation of image quality and should not be considered reason to clean the lens.
2. When absolutely necessary, dust on the front lens should be removed with very gentle strokes of a camel's hair brush or blown off with an ear syringe (available at any pharmacy).
3. Organic materials (e.g., fingerprints) on the front lens may be removed with a photographic lens cleaner solution, using soft, white facial tissues. Make short, gentle strokes and change the tissues often.
4. If the Model 102ACHR/500 telescope is used outdoors on a humid night, water condensation on the telescope surfaces will probably result. While such condensation does not normally cause any damage to the telescope, it is recommended that the entire telescope be wiped down with a dry cloth before the telescope is packed away. Do not, however, wipe any of the optical surfaces. Rather, simply allow the telescope to sit for some time in the warm indoor air, so that the wet optical surfaces can dry unattended.
5. Do not leave the Model 102ACHR/500 telescope inside a sealed car on a warm summer day; excessive ambient temperatures can damage the telescope's internal lubrication.



### #778 Off-Axis Guider

With the #778 Off-Axis Guider placed into the focuser of the 102ACHR/500, the telescopic image may be monitored during long-exposure astrophotography. Any 35mm SLR camera with removable lens may be attached to the #778

guider body by means of a T-mount appropriate to the camera brand.

### Variable-Projection Camera Adapter (1.25")

For astrophotography through the 102ACHR/500, insert the Variable-Projection Camera adapter directly into the focuser drawtube (6), Fig. 6. The camera adapter includes a machined sliding mechanism, permitting variable projection distances during eyepiece-projection photography. A separable thread-in unit also permits prime focus photography. Use with a T-Mount, ordered separately, for your brand of 35mm camera body.



### #1701 Single-Axis Drive System

With the Model 102ACHR/500 telescope polar aligned, the addition of the #1701 Single-Axis Drive System allows the telescope to track on a desired object automatically, keeping the

6. **Never try to disassemble the objective lens of the telescope.** Optimum optical performance is achievable only by means of sensitive adjustments made at the Meade factory, and you will almost certainly not be able to replace the lens components in their correct orientation for high resolution performance.

### **Proper Storage and Transport of the Telescope**

When not in use, store the telescope in a cool, dry place. Do not expose the instrument to excessive heat or moisture.

When transporting the telescope, take care not to bump or drop the instrument; this type of abuse can damage the optical tube and/or the objective lens.

### **Meade Customer Service**

If you have a question concerning your Meade Model 102ACHR/500 telescope, call Meade Instruments Customer Service Dept. at 714-451-1450, or fax at 714-451-1460. Customer Service hours are 8:30AM - 4:00PM, Pacific Time, Monday through Friday. In the unlikely event that your Model 102ACHR/500 telescope requires factory servicing or repairs, write or call the Meade Customer Service Dept. first, before returning the telescope to the factory, giving full particulars as to the nature of the problem, as well as your name, address, and daytime telephone number. The great majority of servicing issues can be resolved by telephone, avoiding return of the telescope to the factory.

## SPECIFICATIONS

### MODEL 102ACHR/500: 4" Achromatic Refracting Telescope

---

<b>Optical Design</b> .....	2-element air-spaced Achromat
<b>Clear Aperture</b> .....	102mm (4.0")
<b>Focal Length</b> .....	920mm
<b>Focal Ratio</b> .....	f/9
<b>Near Focus (approx.)</b> .....	50 ft. (15 meters)
<b>Resolving Power (arc secs.)</b> .....	1.1
<b>Super Multi-Coatings</b> .....	Standard, all surfaces
<b>Limiting Visual Magnitude (approx.)</b> .....	12.0
<b>Limiting Photographic Magnitude (approx.)</b> .....	14.5
<b>Image Scale (degs./inch)</b> .....	1.56°/inch
<b>Maximum Practical Visual Power</b> .....	400x
<b>Optical Tube Dimensions</b> .....	4.5" x 31.5" (11.4 cm x 80 cm)
<b>Focusing Mechanism</b> .....	1.25", Rack & Pinion
<b>Eyepiece Holder</b> .....	1.25"
<b>Diagonal Prism</b> .....	1.25"
<b>Materials:</b>	
<b>Objective Lens</b> .....	BK7; F2
<b>Optical Tube</b> .....	aluminum
<b>Equatorial Mounting</b> .....	aluminum castings
<b>Gears</b> .....	bronze, R.A. and Dec (LXD 500B) aluminum, R.A. and Dec (LXD 500A)
<b>LXD 500 Tripod</b> .....	aluminum
<b>Equatorial Mounting</b> .....	LXD 500; German-type
<b>Tripod</b> .....	Standard
<b>Tripod Legs</b> .....	Inner leg: 1.5" (3.8 cm) O.D. Outer leg: double strut 1.2" (3.0 cm) O.D. each
<b>Tripod Height</b> .....	28.5" - 48.5" variable (72.4 cm - 123.2 cm)
<b>Counterweights</b> .....	2 X 7.5 lb (3.4 kg)
<b>Worm Gear Diameters</b> .....	2.91" (7.39 cm)
<b>Setting Circle Diameters</b> .....	R.A. & Dec: 3.4" (8.6 cm)
<b>Manual Slow-Motion Controls</b> .....	R.A. and Dec
<b>Latitude Range</b> .....	15° - 70°
<b>Total Net Telescope Weight</b> (b approx., with mount & tripod) .....	47.5 lb (21.6 kg)
<b>Heaviest Sub-Section for Field Assembly</b> .....	19.5 lb (8.9 kg)
<b>Shipping Weight (approx.)</b> .....	62.0 lb (28.1 kg)

---

## MEADE LIMITED WARRANTY

Every Meade telescope, spotting scope, and telescope accessory is warranted by Meade Instruments Corporation ("Meade") to be free of defects in materials and workmanship for a period of ONE YEAR from the date of original purchase in the U.S.A. and Canada. Meade will repair or replace a product, or part thereof, found by Meade to be defective, provided the defective part is returned to Meade, freight-prepaid, with proof of purchase. This warranty applies to the original purchaser only and is non-transferable. Meade products purchased outside North America are not included in this warranty, but are covered under separate warranties issued by Meade international distributors.

**RGA Number Required:** Prior to the return of any product or part, a Return Goods Authorization (RGA) number **must** be obtained from Meade by writing, or by calling (714) 451-1450. Each returned part or product must include a written statement detailing the nature of the claimed defect, as well as the owner's name, address, and phone number.

This warranty is not valid in cases where the product has been abused or mishandled, where unauthorized repairs have been attempted or performed, or where depreciation of the product is due to normal wear-and-tear. Meade specifically disclaims special, indirect, or consequential damages or lost profit which may result from a breach of this warranty. Any implied warranties which can not be disclaimed are hereby limited to a term of one year from the date of original retail purchase.

This warranty gives you specific rights. You may have other rights which vary from state to state.

Meade reserves the right to change product specifications or to discontinue products without notice.

This warranty supersedes all previous Meade product warranties

---



# Meade Instruments Corporation

*World's leading manufacturer of astronomical telescopes for the serious amateur.*

6001 Oak Canyon, Irvine, California 92620-4205 ■ (714) 451-1450

Fax: (714) 451-1460 ■ [www.meade.com](http://www.meade.com)