



C90mm Mak - #52265

Congratulations on your purchase of a Celestron spotting scope! Whether your interest lies in nature or astronomy this spotting scope offers the finest in optical quality guaranteed to give you years of viewing pleasure.



Figure 1-1

The Eyepiece

Your C90 Mak has an internal flip mirror that can divert light either through the 90° eyepiece barrel at the top of the rear cell or directly through the erect image diagonal (for daytime use) at the rear of the spotting scope. Make sure that the flip mirror is in the "down" position for viewing with an eyepiece at 90° and in the "up" position for viewing through the diagonal (see Figure 1-2).

To install the eyepiece directly into the 90° eyepiece barrel (for astronomical use):

1. Loosen the thumbscrew on the eyepiece barrel so it does not obstruct the inner diameter of the barrel.
2. Slide the chrome portion of the eyepiece into the eyepiece barrel.
3. Tighten the thumbscrew to hold the eyepiece in place.
4. To remove the eyepiece, loosen the thumbscrew on the eyepiece barrel and slide the eyepiece out.

To install the eyepiece onto the rear of the spotting scope (for land use):

1. Unthread the cap from the rear cell.
2. Thread the metal ring of the erect image diagonal onto the threads of the rear cell.
3. Remove the caps and loosen the thumbscrew on the diagonal so it does not obstruct the inner diameter of the barrel
4. Slide the chrome portion of the eyepiece into the eyepiece barrel.
5. Tighten the thumbscrew to hold the eyepiece in place.

The Finderscope

The C90 Mak comes with a 8x21mm erect image finder. The first number used to describe the finder is the power. The second number is the diameter of the objective lens in millimeters. For example, the C90 Mak finder is 8x21 which means it is 8 power and has a 21mm objective lens. Incidentally, power is always compared to the unaided human eye. So, an 8 power finder magnifies images eight times more than the human eye. The finderscope is adjusted using the three adjustment screws located 120° around each finderscope ring.

The finderscope comes pre-assembled and is mounted inside the finderscope bracket rings. To attach the finderscope:

1. Loosen the set screw on the mounting bracket on the spotting scope (see Figure 1-3).
2. Slide the finder bracket (with finderscope attached) into the mounting bracket on the spotting scope.
3. The finderscope bracket will slide in from the back. The finderscope should be oriented so that the objective lens is toward the front end of the spotting scope.
4. Tighten the set screw on the mounting bracket to hold the finderscope in place.

Aligning the Finderscope:

To make things a little easier, you should align the finder during the day when it is easier to locate objects. To align the finder:

1. Choose a conspicuous object that is over 500 yards away. This will eliminate any possible parallax effect.
2. Point your spotting scope at the target and center it in the main optics of the spotting scope (the eyepiece).
4. Check the finder to see where the object is located in the field of view.
5. Adjust the screws on the finder bracket, tightening one while loosening another, until the cross hairs are centered on the target.

Accurate alignment of the finder will make it much easier to find objects in the main optical tube.

Focusing

The C90 Mak spotting scope focusing mechanism controls the position of the primary mirror which slides back and forth on the primary baffle tube. Turn the focusing knob until the image is sharp. If the knob will not turn, the primary mirror has reached the end of its travel on the focusing mechanism. Turn the knob in the opposite direction until the image is sharp. Once an image is in focus, turn the knob clockwise to focus on a closer object and counterclockwise for a more distant object. A single turn of the focusing knob moves the primary mirror only slightly. Therefore, it will take many turns to go from close focus (approximately 20 feet) to infinity. For astronomical



Figure 1-2 – Flip mirror shown in the "down" position for viewing from the top of the rear cell.

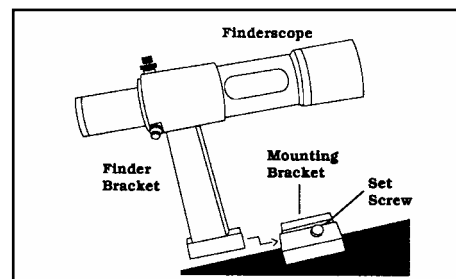

Figure 1-3 – The finderscope and quick-release bracket.

viewing, out-of-focus star images are very diffuse making them difficult, if not impossible, to see. If you turn the focus knob too quickly, you can go right through focus without seeing the image. For best results, your first astronomical target should be a bright object (like the Moon) so that the image is visible even when out of focus.

Calculating Magnification

To determine the magnification of your spotting scope, simply divide the focal length of the spotting scope by the focal length of the eyepiece used. In equation format, the formula looks like this:

$$\text{Magnification} = \frac{\text{Focal Length of Spotting scope (mm)}}{\text{Focal Length of Eyepiece (mm)}}$$

Let's say, for example, you are using the 32mm Plossl eyepiece. To determine the magnification you simply divide the focal length of your spotting scope (1200mm) by the focal length of the eyepiece, 32mm. Dividing 1200 by 32 yields a magnification of 38 power.

Although the power is variable, each instrument under average skies has a limit to the highest useful magnification. The general rule is that 60 power can be used for every inch of aperture. For example, the C90 is 3.5 inches in diameter. Multiplying 3.5 by 60 gives a maximum useful magnification of 210 power. Although this is the maximum useful magnification, most observing is done in the range of 20 to 35 power for every inch of aperture which is 70 to 123 times for the C90 spotting scope.

Attaching a Camera

With the use of an optional photographic T-adaptor (#93635-A) and camera specific T-ring, a 35mm camera can be attached to the rear cell of the spotting scope. To attach a camera to your C90 Mak:

1. Remove the erect image diagonal and eyepiece from the rear cell of the tube.
2. Thread the T-Ring onto the T-Adapter.
3. Mount your camera body onto the T-Ring the same as you would any other lens.
4. Thread the T-Adapter onto the back of the C90 by rotating the slip ring clockwise while holding the camera in the desired orientation (either vertical or horizontal).

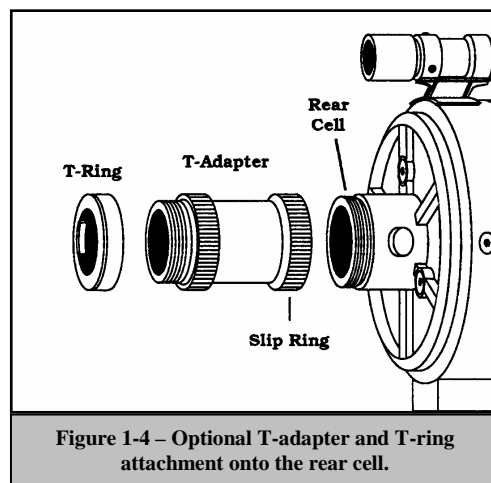

Figure 1-4 – Optional T-adaptor and T-ring attachment onto the rear cell.

Technical Specifications

Model	52265
Optical Design	Maksutov-Cassegrain
Aperture (mm)	90
Focal Length (mm)	1200
Eyepiece	32mm
Angular Field of View (FOV°)	1.4°
Linear FOV (ft. @ 1000 yd)	73ft
Eye Relief	22mm
Near Focus	20ft
Coating	Multi-Coated
Length	11 in
Weight	3.1 lbs

All specifications given with standard eyepiece and are subject to change without notice.

CELESTRON LIMITED LIFETIME WARRANTY

- A. Celestron warrants this spotting scope to be free from defects in materials and workmanship for its usable lifetime. Celestron will repair or replace such product or part thereof which, upon inspection by Celestron, is found to be defective in materials or workmanship. As a condition to the obligation of Celestron to repair or replace such product, the product must be returned to Celestron together with proof-of-purchase satisfactory to Celestron.
- B. The Proper Return Authorization Number must be obtained from Celestron in advance of return. Call Celestron at (310) 328-9560 to receive the number to be displayed on the outside of your shipping container.

All returns must be accompanied by a written statement setting forth the name, address, and daytime telephone number of the owner, together with a brief description of any claimed defects. Parts or product for which replacement is made shall become the property of Celestron.

The customer shall be responsible for all costs of transportation and insurance, both to and from the factory of Celestron, and shall be required to prepay such costs.

Celestron shall use reasonable efforts to repair or replace any spotting scope covered by this limited warranty within thirty days of receipt. In the event repair or replacement shall require more than thirty days, Celestron shall notify the customer accordingly. Celestron reserves the right to replace any product which has been discontinued from its product line with a new product of comparable value and function.

This warranty shall be void and of no force of effect in the event a covered product has been modified in design or function, or subjected to abuse, misuse, mishandling or unauthorized repair. Further, product malfunction or deterioration due to normal wear is not covered by this warranty.

CELESTRON DISCLAIMS ANY WARRANTIES, EXPRESS OR IMPLIED, WHETHER OF MERCHANTABILITY OF FITNESS FOR A PARTICULAR USE, EXCEPT AS EXPRESSLY SET FORTH HEREIN.

THE SOLE OBLIGATION OF CELESTRON UNDER THIS LIMITED WARRANTY SHALL BE TO REPAIR OR REPLACE THE COVERED PRODUCT, IN ACCORDANCE WITH THE TERMS SET FORTH HEREIN. CELESTRON EXPRESSLY DISCLAIMS ANY LOST PROFITS, GENERAL, SPECIAL, INDIRECT OR CONSEQUENTIAL DAMAGES WHICH MAY RESULT FROM BREACH OF ANY WARRANTY, OR ARISING OUT OF THE USE OR INABILITY TO USE ANY CELESTRON PRODUCT. ANY WARRANTIES WHICH ARE IMPLIED AND WHICH CANNOT BE DISCLAIMED SHALL BE LIMITED IN DURATION TO A TERM OF ONE YEAR FROM THE DATE OF ORIGINAL RETAIL PURCHASE.

Some states do not allow the exclusion or limitation of incidental or consequential damages or limitation on how long an implied warranty lasts, so the above limitations and exclusions may not apply to you.

This warranty gives you specific legal rights, and you may also have other rights which vary from state to state.

Celestron reserves the right to modify or discontinue, without prior notice to you, any model or style spotting scope.

If warranty problems arise, or if you need assistance in using your spotting scope contact:

Celestron
Customer Service Department
2835 Columbia Street
Torrance, CA 90503
Tel. (310) 328-9560
Fax. (310) 212-5835
Monday-Friday 8AM-4PM PST

All authorized returns should be shipped to:

Celestron
1380 Charles Willard St.
Carson, CA 90747

This warranty supersedes all other product warranties.

NOTE: This warranty is valid to U.S.A. and Canadian customers who have purchased this product from an Authorized Celestron Dealer in the U.S.A. or Canada. Warranty outside the U.S.A. and Canada is valid only to customers purchased from a Celestron International Distributor or Authorized Celestron Dealer in the specific country and please contact them for any warranty service.

