

TELESCOPE ТАА -2 (ТАА-2Т)

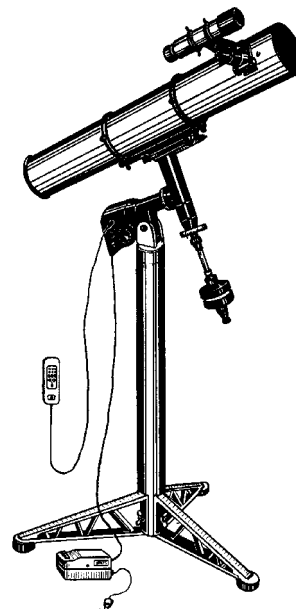

SERVICE MANUAL



CONTENTS

	Page
1. General directions	3
2. Specifications	4
3. Standard equipment	5
4. Design and principle of operation of telescope	6
5. Preparation for operation	15
5.1. Telescope assembling	15
5.2. Telescope balancing	16
5.3. Precautionary measures	16
6. Order of operation	19
6.1. Operation with telescope	19
6.2. Photographic observations	21
6.3. Telescope and atmospheric conditions	22
7. Maintenance	23
8. Possible derangements and methods of their elimination	24
9. Rules of storage	26
10. Acceptance certificate	26
Supplement. Table of close stellar pairs for testing image quality of telescope	27

The telescope is subject to continuous development and improvement, consequently it may incorporate minor changes in detail from the information contained herein.

11.01



1. GENERAL DIRECTIONS

ATTENTION!

The telescope forms the inverted image like any astronomical instrument does.

The direct observations of the Sun through the black light filter are permitted only with the use of a solar diaphragm.

Telescope TAA-2 (TAA-2T) (hereinafter in the text referred to as "telescope") is designed for visual observation of the celestial objects.

The telescope can operate normally at the ambient temperature from 30°C to minus 30°C.

When buying the telescope one should pay attention to the package safety ensured by the seal of the manufacturing plant.

After unsealing the case one should check compliance of the complete set denoted in the list of enclosure. Prior to using the telescope one gets acquainted with its handling and order of operation.

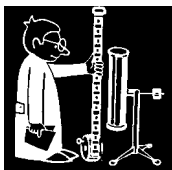

2. SPECIFICATIONS

Diameter of primary mirror	150mm
Focal ratio	f/8
Focal length	1200mm
Magnifications:	
-with the eyepiece of $f'=40$ mm	30 \times
-with the eyepiece of $f'=25$ mm	47 \times
-with the eyepiece of $f'=7.5$ mm	60 \times
-with the eyepiece of $f'=40$ mm and Barlow lens	95 \times
-with the use eyepiece of $f'=25$ mm and Barlow lens	158 \times
-with the eyepiece of $f'=7.5$ mm and Barlow lens	317 \times
Angular field of view of the telescope at magnification:	
30 \times	1 $^{\circ}$ 12'
47 \times	1 $^{\circ}$
60 \times	0 $^{\circ}$ 29'
95 \times	0 $^{\circ}$ 29'
158 \times	0 $^{\circ}$ 17'
317 \times	0 $^{\circ}$ 8'
Resolution	1"
Limiting magnitude	12 ^m
Range of slow-motion control on the declination axes	$\pm 4^{\circ}$
Rotation of the telescope:	
in right ascension	360 $^{\circ}$ (24h)
in declination	360 $^{\circ}$
Polar axis altitude adjustment	0 $^{\circ}$ to 70 $^{\circ}$
Minimum distance of observation, mm	440
Voltage of the supplying mains	220/110 \pm 10 $^{\circ}$
Current frequency	50Hz (60Hz)
Output voltage of supply unit, V	12 \pm 10 $^{\circ}$
Angular field of view of the finderscope	7 $^{\circ}$
Magnification of the finderscope	8 \times
Sizes of the telescope:	
length tube	1200mm
height in the operating position	1700mm
Weight of the telescope, maximum	40kg



3. STANDARD EQUIPMENT

Name	Qty
Telescope	1
Supply unit	1
Eyepiece of $f'=40$ mm	1
Support	3*
Finderscope of 8x magnification	1
Pier	1*
Tripod	1*
Equatorial mounting	1
Bundled conductors	1
Bracket	2
Control panel	1**
Cable for car mains	1**
Accessories and Parts	
Reticle	1
Barlow lens	1
Eyepiece of $f'=25$ mm	1
Eyepiece of $f'=7.5$ mm	1
Yellow light filter	1
Black light filter (solar)	1
Blue light filter	1
Red light filter	1
Green light filter	1
Neutral light filter (gray, lunar)	1
Blind 1	
Fuse link ВГТТ 19-0.16А (220V)	2
Fuse link ВГТТ 19-0.32А (110V)	2
Cover	1
Adapter	1
Stopper	1
Brush	1
Cap	1
Screwdriver	1

Name	Qty
Napkin	1
Screen (for observation of the Sun)	1
Market Containers	
Housing	1
Housing	1
Service documents	
Service manual	1

* Telescope can be completed with a metal pier (TAA-2) or tripod (TAA-2T)

** Optional accessories



4. DESIGN AND PRINCIPLE OF OPERATION OF TELESCOPE

The telescope consists of four basic units: the telescope tube, equatorial mounting, pier with supports or tripod, supply unit.

The tube 5 (fig. 1) is the basic part of the telescope which embodies the optical units: a primary mirror, a diagonal mirror, finderscope 3 fixed in the locating rings 4, eyepieces and Barlow lens which are inserted in focusing mechanism 1.

The primary mirror (fig. 3) is mounted in the cell and can be adjusted by means of the screws and 2.

The diagonal mirror (fig. 4) is cemented to the cell and fixed in the telescope tube by means of a spider. The inlet hole of the tube is covered with cap 3 (fig. 9) after operation.

Finderscope 3 (fig. 1) is a scope with 8x magnification and field of view of 7°.

The focusing mechanism 1 (fig. 1) is composed of a rack and pinion. The pinion axle carries the handwheels which help to move the eyepiece

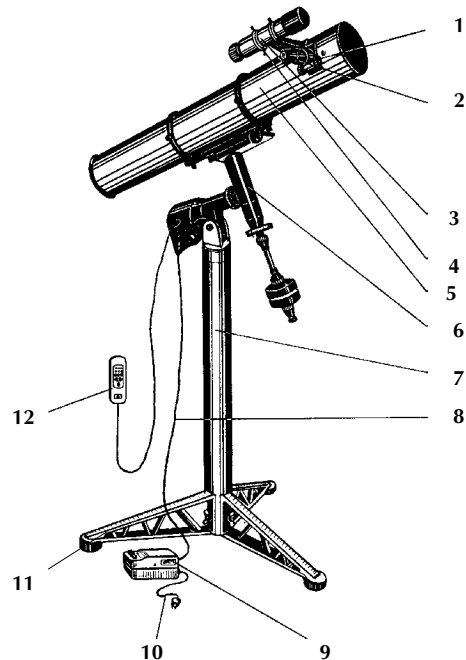

Fig. 1. General view of telescope with metal pier:

- 1 - focusing mechanism; 2 - bushing; 3 - finderscope; 4 - ring;
- 5 - telescope tube; 6 - equatorial mounting; 7 - pier;
- 8 - bundled conductors; 9 - supply unit; 10 - cord; 11 - supports;
- 12 - control panel

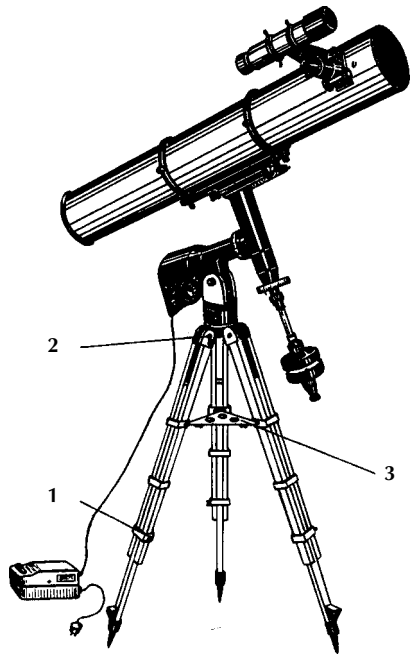

Fig. 2. **General view of telescope with tripod:**
1,2 - stops; 3 - objects table

tube. The smoothness of the tube movement can be controlled. For this purpose the left handwheel is held by one hand and the right handwheel is rotated clockwise (with some effort) relative to the left handwheel by the other hand. The chosen position of the tube can be fixed in this way, if necessary.

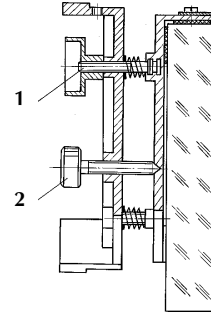

Fig. 3. **Primary mirror:**
1 - set screw; 2 - adjusting screw

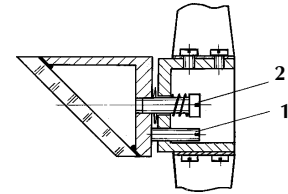

Fig. 4. **Diagonal mirror:**
1 - adjusting screw; 2 - set screw

The telescope is complete with six light filters 6 (fig. 9)

The **equatorial mounting** (fig. 5) consists of polar axes 10 and declination axis 3 perpendicular to the polar axis.

Fastened on one end of the declination axis is the saddle with hinged clips 1 in which the telescope tube is mounted; fastened on the other end of the axis is the counterweights 5 which can move along the axis for balancing the telescope tube. Solar-screen 1 (fig. 9) can be fastened on the same axis as well.

The casing of the polar axis is fastened on the bracket 7 (fig. 5) provided with a scale of latitudes by which the polar axis is set to the latitude of the observer's site.

The southern (lower) end of the polar axis embodies electric clock drive 8, the northern (upper) end embodies the casing of declination axis 3.

Both axes are provided with a setting circles which shows an hour angle or declination of the object visible in the telescope field of view. Setting circle 4 on the declination axis which shows the object

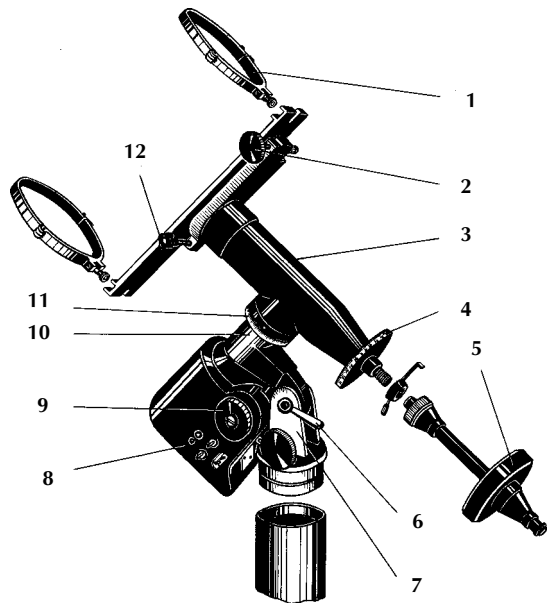

Fig. 5. Equatorial Mounting:

- 1 - folding clips; 2 - micrometer screw of slow-motion mechanism;
- 3 - declination axis; 4 - circle of declinations; 5 - counterweights;
- 6 - bolt; 7 - bracket with scale of latitudes; 8 - electric watch drive;
- 9 - handwheel of micrometer screw of polar axis;
- 10 - polar axis; 11 - circle of hour angles; 12 - screw of axis brake

declination is figured from 0 to 90° with a division value of 1°. Circle 11 positioned on the polar axis (the circle of hour angles) is figured from 0 to 24 hours with a division value of 10 minutes.

The declination axis has braking screw 12 and mechanism 2 of slow motion which moves the tube in the range of $\pm 4^\circ$. By using this mechanism it is possible to correct the position of the object in the field of view. The equatorial mounting is connected to the pier.

Pier 7 (fig. 1) consists of a pipe with three supports 11.

The tripod (fig. 2) allows to adjust a height of telescope and to fix each leg of tripod with the help of stops 1 and 2.

Supply unit 9 (fig. 1) powers the watch drive tracking the celestial objects. It is designed for 220 V/ 50 Hz (110V/60Hz) mains and activated with the key. If the control panel is provided the car's mains or storage battery 12 V can be used through the car's cable.

The control panel (fig.6) is designed to select modes of watch drive by means of buttons 2. The watch drive provides the sun, celestial and moon speed modes. The control panel is equipped with the local lighting which can be switched on by button 4.

The reflecting telescope is the Newton optical system (fig. 7). The parallel beam of rays enters the telescope tube, falls on the primary mirror 1 and, after reflecting from it deflects by diagonal mirror 3, at 90° and is viewed with the help of the eyepiece 2.

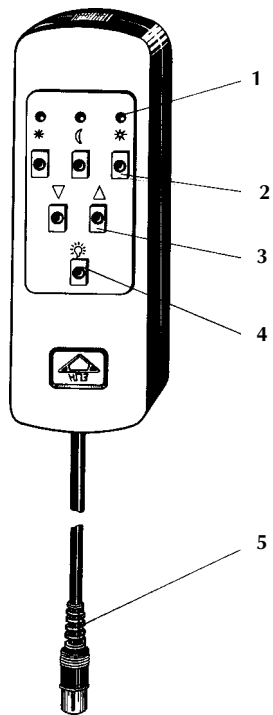

Fig 6. Control Panel:

1 - indicator; 2 - speed selection buttons; 3 - correction buttons;
4 - lighting button; 5 - plug

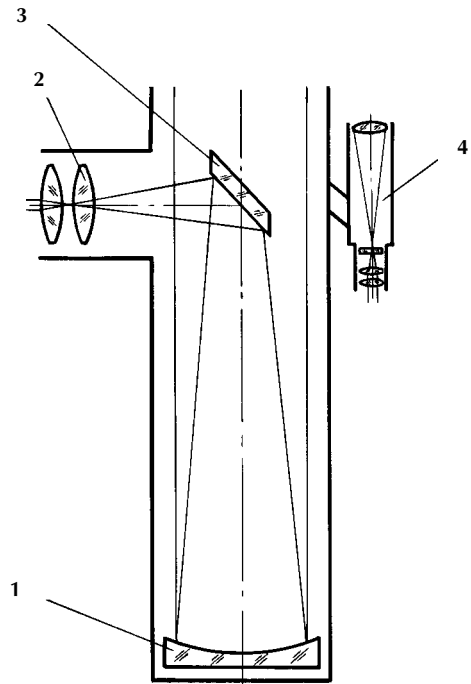

Fig. 7. Optical train of telescope:

1 - primary mirror; 2 - eyepiece; 3 - diagonal mirror; 4 - finderscope

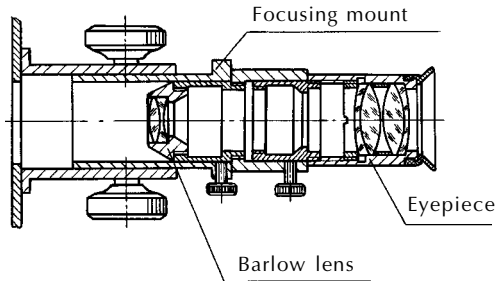
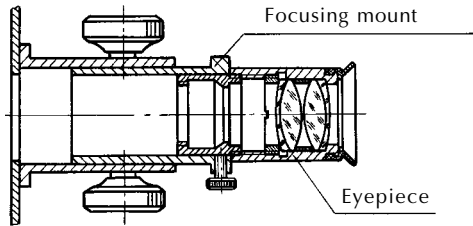
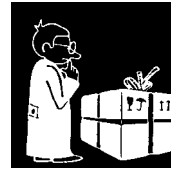

Fig. 8. Diagram of setting Barlow lens



5. PREPARATION FOR OPERATION

5.1. Telescope assembling

Prior to assembling the units and parts should be cleaned from the slushing compound of the plant.

The telescope is assembled in the following way.

Three supports provided with captive screws are fixed to the lower end of the pier through holes. The equatorial mounting is set on the upper end of the pier. At the same way it is fixed on the tripod.

In order to aim the polar axis turn the equatorial mounting by the value of the observation site latitude by means of elevation gear and latitude scale. Lock the direction adjusted with the lock handle.

Mount the axle with the counterweight 5 (fig. 4) on the declination axis unit and fasten it with the nut. Mount the clips 1 on the bracket and then the telescope 5 in them (fig.1).

The telescope tube is mounted on the supports of the saddle and fixed by means of two clips with the help of hinged screws.

The finderscope is mounted on the tube in two rings and fixed with six set screws available on the rings.

In transportation and storage a hole in the eyepiece tube is plugged with a stopper which should be removed and put in the case in preparation for operation.

For obtaining the required magnification of the telescope the respective eyepiece or the eyepiece with Barlow lens 4 (fig. 9) is inserted in the eyepiece tube.

A toggle switch of the supply unit is to be set in position "0".

Connect bundled conductors 8 (fig. 1) to the clock drive and to the supply unit through a socket designated, connect a plug of cord 10 of the supply unit to the mains of 220/110V. Set the toggle switch of the supply unit in position "I", set the toggle switch of the drive in position "II". A light indicator on the clock drive must light.

The control panel if provided is connected to the mounting by means of the plug 5 (fig. 6).

Set the switch of control panel operation on the mounting into "I" position. The watch drive is activated by one of the buttons 3. When it

operates the indicator lights. The switch of autonomous operation on the mounting and the key of supply unit must be set into "I" position previously.

5.2. Telescope balancing

For smooth motion of the telescope and reliable operation of the slow motion knob it is important to balance its movable parts on the axes of the equatorial mounting.

For this purpose one should set the telescope tube in the horizontal position, unscrew the bolt of brake 6 (fig. 5) of the declination axis and holding slightly the tube by hand see to it whether it remains in the indifferent equilibrium. If the tube is not in balance, undo the screws of the clips which fix the tube and move the tube along its axis until it will be in balance. After that one screw in the screws of the clips.

For balancing the telescope relative to the polar axis it is necessary to set the declination axis in the horizontal position. Then it is necessary to slacken each of three screws 12 through cap 11 of the watch drive (fig. 10). Holding the axis by hand see to it whether the telescope is in balance about the polar axis. If the telescope is not in balance, move counterweight 8 (fig. 5) along the declination axis. After balancing tighten screws 12 of the friction clutch (fig. 10) on the polar axis so that the telescope can not rotate easily.

The adjustment of the friction clutch is considered to be finished if the telescope tube moves due to the minor effort of the hand.

When mounting the various devices on the telescope, for example, a camera, it is required to balance the telescope additionally.

5.3. Precautionary measures

The rate of the fuse link mounted in the supply unit must be in compliance with the rate denoted under the fuse link holder.

Mount the fuse link only after complete disconnection of the supply unit from the mains.

Connect the bundled conductors to the watch drive and supply unit when the supply unit is disconnected from the mains.

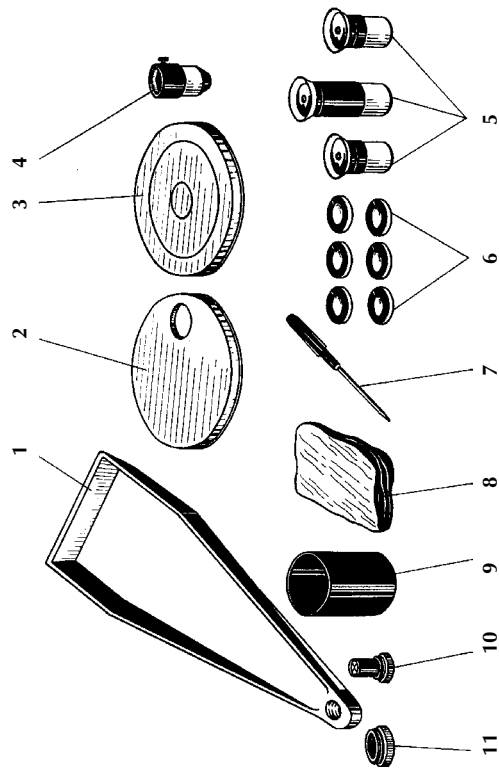

Fig. 9. Tools and accessories:

1 - solar screen; 2 - cap-diaaphragm; 3 - cap; 4 - Barlow lens; 5 - eyepieces; 6 - light filters; 7 - screwdriver; 8 - napkin; 9 - blind; 10 - reticle; 11 - adapter

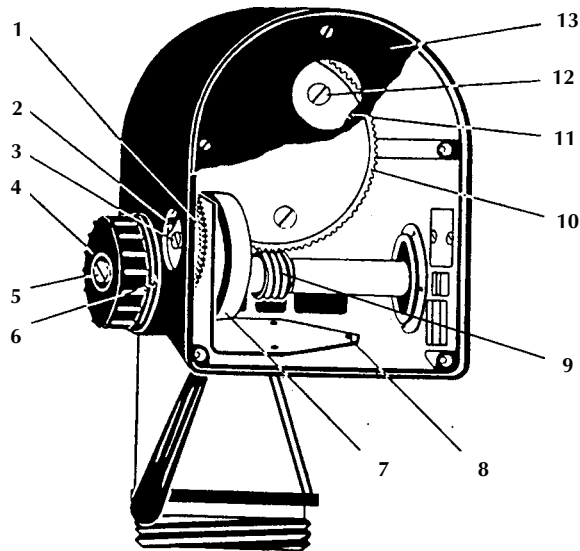

Fig. 10. Watch drive:

- 1 - worm gear wheel; 2 - cap; 3 - screw; 4 - handwheel; 5 - screw;
- 6 - screw; 7 - motor; 8 - screw; 9 - worm with gear wheel;
- 10 - worm wheel; 11 - cap; 12 - screw; 13 - cover



6. ORDER OF OPERATION

6.1. Operation with telescope

Before mounting the telescope it is required to choose a place and prepare a site. It must be even and solid. Mount the telescope on the site and check it for reliable stability.

For pointing to an object the telescope should be rotated about two axes. For rotation of the declination axis it is necessary to undo braking screw 12 (fig. 5), rotate the telescope and screw in the bracking screw.

If backlash is arisen in the worm gear it is necessary to disengage motor 7 (fig. 10). For this purpose it is required to take off cap 13, slacken three screws 8, displace motor 7 upwards and fix it with screws 8. Remove handwheels 4 after unscrewing screws 5. After that slacken screws 6 which fasten worm 9 in the bearings. After pressing the worm to worm wheel 10 fix it with screws 6. Mount handwheels 4 and secure them with screws 5. Then slacken screws 8, displace the motor downwards until engagement with the toothed wheel of the worm takes place and secure them with screws 8. Mount cap 13 on the casing.

The smoothness of rotation of toothed wheel 1 together with the toothed wheel of worm 9 is checked by rotation of the handwheels, in doing so probable sliding or jamming of the friction clutch may take place.

For its adjustment it is required to displace cap 2 and tighten or slacken three screws 3. The friction clutch adjustment is considered to be finished if handwheels 4 rotate smoothly.

The telescope rotates about the polar axis owing to minor effort and is not fixed. The axis is connected to the watch drive with the help of a friction mechanism.

The celestial sphere and all astronomical objects perform a complete rotation for twenty four hours. As a result the object in the telescope field of view displaces constantly. The speed of its displacement increases with the increase of the telescope magnification. Therefore, the telescope is provided with electric clock drive 8 (fig. 5) which rotates uniformly the telescope which follows the object. As a result, in the process of observation the object remains constantly at the centre of the field of view.

In the process of observation it is often required to perform minor corrections in the diurnal run of the telescope. For this purpose one makes use of handwheels 4 (fig. 10) or the buttons 3 (fig. 5) of the control panel. The buttons 3 speed up or slow down the tracking speed of the watch drive relative to the nominal providing the correction of right ascension angle. The correction modes are activated when one of the buttons 3 is pressed continuously and the indicator 1 blinks. If the button 3 is released the tracking speed returns to the nominal.

The telescope has high magnifications and, hence, small fields of view, therefore it is provided with a finderscope.

After mounting the telescope it is necessary to set parallel of the optical axes of the telescope tube and finderscope. For this purpose one should mount a reticle with cross into the eyepiece $\Gamma=25$ mm. One should make an adjustment by remoted object.

By operating with the set screws of rings 4 (fig. 1) of the finderscope one brings the chosen remote object to the centre of the finderscope field of view. This operation is performed once. In the future before observation only a check-up of parallelism of the telescope and finderscope optical axes is needed.

In order to avoid corrections of the declination axis during operation of the watch mechanism it is required to set the telescope polar axis in parallel to the celestial axis. In this case the northern (upper) end of the polar axis faces the celestial pole positioned near Polaris (a Ursae Minoris). For visual observations it is enough to incline the polar axis at an angle equal to the latitude of the observing site and direct it approximately along the line the South - the North. With such coarse setting of the telescope the object will "deviate" step by step in declination (it is lifted or lowered in the field of view). This error is corrected at times by means of the micrometer screw of the declination axis.

For photographic operations and in the case when the telescope can be set stationary, the polar axis of the telescope should be set precisely. For this purpose one observes any bright star in the East, then in the South and makes notice of the direction of the star displacement.

If in observation of the star in the East it is displaced in the telescope field of view so that in its tracking the upper end of the telescope tubes sinks slowly, the north end of the polar axis should be somewhat lifted.

If the upper end of the tube is lifted step by step, the north (upper) end of the polar axis should be lowered.

For precise setting of the axis by azimuth one observes the star near the meridian circle (above the south point) in the same way. If in the star tracking one has to lower slowly the upper end of the

telescope tube, the north end of the polar axis should be displaced to the West. If in the process of the star tracking the upper end of the telescope tube is lifted, the north end of the polar axis should be displaced to the East.

In 20-30 minutes of such observations one can set the polar axis so that the star will remain on the cross-hairs for 10-15 minutes without correction in declination.

After precise setting of the polar axis one can set the declination and hour circles which must help to search the objects invisible with a naked eye or even through the finderscope.

First of all one should set the hour circle which is fixed on the polar axis. After a fine setting of the polar axis set the declination axis horizontally. The horizontal setting should be checked with the aid of a level. After setting of the axis one sets the hour circle so that "0" is found against the index. Fix the circle by means of screws.

For setting the declination circle fixed on the declination axis one should find the declination of two-three bright stars in the star catalogue or make use of the declinations of the planets. With the help of the finderscope one brings the star or the planet to the centre of the field of view of the telescope at maximum magnification. After that one sets the declination of the required star against the index. The circle is to be fastened with a screw. Then one makes attempt to find the second star by its declination. For this purpose one slackens the screws of the axis brake and adjusts the telescope so that the declination of the star to be sought is set on the declination circle. Fix the declination axis and, by rotating the telescope tube slowly clockwise and counter-clockwise around the polar axis, one brings the star to the centre of the telescope field of view. After checking of the circle setting one tightens it with a nut.

In order to avoid resetting of the polar axis and circles one should choose a solid horizontal site. Best of all it is made of some concrete of 1.5x1.5 m size. The position of three supports of the telescope pier should be marked on this site. The telescope is mounted according to the marks on the concrete site.

6.2. Photographic observations

Photographing star fields is carried out with the use of the telescope in Newtonian focus. To make it one should use a small size 35 mm camera which is set on focusing mechanism directly or with the help of adapter 11 (fig. 9). After setting of camera it is necessary to balance the telescope.

The exposures which are required for photographing the star fields are tenths of minutes without hindrance of the street lighting. Therefore, for this period of time one should see to it that the camera follows the sky precisely in its diurnal rotation. Near the centre of the field of view of the camera one chooses the bright star to which the telescope is pointed. To keep the star on the reticle cross-hairs of the finderscope is the problem for an observer for the whole period of exposure. As the cross-hairs of the finderscope is not illuminated, the image of the guide star should be slightly defocused in order to cross a light circle of the unsharp image of the star by the cross-hairs and to keep the star in this position for the period of exposure.

One applies minor corrections for a clock-work drive with the help of handwheel 9 (fig. 5) keeping the star on the cross-hairs for the whole period of exposure. One corrects the position of the guide star with the micrometer screw of the declination axis if necessary. To obtain the minimum corrections in declination the polar axis should be set as precisely as possible to the celestial pole. One should remember that if the polar axis is set incorrectly, even in the case when the star image is kept on the cross-hairs, the images of the stars at the edges of the field of view appear as dashes.

6.3. Telescope and atmospheric conditions

At high magnifications together with the increase of the visible dimensions of the object the disturbances due to atmosphere are increased. They are expressed in great blurring of the images of the distant objects, in scintillation and blurring of the star images.

The observation in the cold seasons are possible when all telescope parts acquire the ambient temperature. For air circulation inside the telescope tube there is a hole plugged with a stopper in the cell of the primary mirror. In operation the stopper should be unscrewed from the cell.

But in observations in the street the great disturbance of atmosphere may take place at nights, that leads to bad images of the celestial objects.

It is quite possible that at those nights the observations of the fine details of the planets and of the Moon are unsuccessful.

It is apparent that the observations with the aid of the telescope through the window are senseless as the rough surfaces of the window glasses distort the images.

In case of precipitation and stopping of operation the telescope together with supply unit must be covered.



7. MAINTENANCE

For faultless operation the telescope should be kept in cleanness and protected against mechanical damage. The metal surfaces are periodically dusted by using clean soft napkins, then wiped with a napkin impregnated with acidless vaseline, after that with a dry napkin.

The aluminized mirrors require particular care. The accumulated dust is removed only with the use of a soft brush or cotton wool tampon. Cleaning should be carried out without excessive effort to avoid formation of thin scratches on the mirrors surface which deteriorate the image. If some fat spots are found on the mirrors, never wipe them. In this case the mirrors are washed. The primary mirror (fig. 2) is taken out of the tube after unscrewing the screws which fix the cell to the tube. Without removing the mirror from the cell, the mirror surface is wetted considerably with pure medical alcohol with the help of a cotton wool tampon. By using the same tampon, one wipes slightly the wet mirror without excessive effort and puts it at once under the stream of pure water. After removing alcohol in this way, one puts the mirror on its edge until it is dried. The drops of water are removed with a blotter by slight touching them with a blotter corner.

The diagonal mirror is cleaned in the same way. After cleaning the mirrors are put in their places.

The lenses of the eyepieces are wiped with a dry linen napkin. The fat spots are removed with a cotton wool piece impregnated with alcohol.

One should dismantle the optics only in case of necessity. In non-operating position the telescope tube must be constantly covered with a cap and the eyepiece one is to be plugged with a stopper.



8. POSSIBLE DERANGEMENTS AND METHODS OF THEIR ELIMINATION

When manufacturing the telescope at the plant, the optical pieces are carefully set (adjusted), relative to each other. However, in case of transportation or considerable impacts of the telescope the optical pieces may be displaced (the adjustment is disturbed). In this case it is required to readjust the telescope. Prior to this operation one should remove the eyepiece from the eyepiece tube and check whether the mirrors are displaced from the given places. For this purpose it is necessary to look through the eyepiece tube from which the eyepiece and the Barlow lens are removed. If the telescope is adjusted, the plane diagonal mirror must be concentric relative to the brim of the focusing mount. The reflection of the primary mirror in the diagonal one must be concentric as well. The reflection of the diagonal mirror with the spider system is seen in the primary mirror. The image of the diagonal mirror must be positioned precisely in the middle of the primary one.

The reflection of an observer's eye (fig. 11) must be seen at the centre of the diagonal mirror reflection.

In adjustment it is required to correct the position of the diagonal mirror or primary one. If the image of the primary mirror in the diagonal one is non-concentric it is necessary to change the position of the diagonal mirror. For this purpose one unscrews screw 2 of the cell of the diagonal mirror (fig. 4) and, operating with one of screws 1, brings the reflection of the primary mirror in the diagonal one to the centre of the diagonal mirror.

If the position of the primary mirror is disturbed, the reflection of the diagonal mirror with the spider in it is seen not at the centre. In this case one unscrews screws 2 of the cell of the primary mirror and, by operating with three screws 1 (fig. 3), sets the primary mirror so that the reflection of the diagonal mirror in it is found at the centre (becomes concentric). After setting the mirror in the correct position, one fixes the cell in position by means of screws 2.

The adjustment of the telescope is delicate and is carried out only in case, of emergency, when it is clear that the telescope is misadjusted and its mirrors and reflections from them are not concentric.

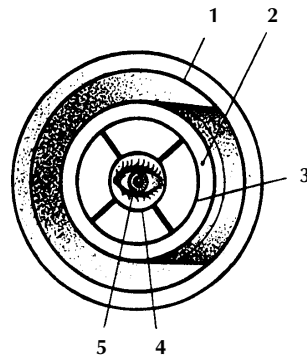

Fig. 11. Setting concentricity of mirrors:

- 1 - inner diameter of focusing mount; 2 - diagonal mirror;
- 3 - reflection of primary mirror in diagonal;
- 4 - reflection of diagonal mirror in primary one; 5 - observer's eye

9. RULES OF STORAGE

It is recommended practice to store the telescope in the case in the heated premises with relative humidity of maximum 80%, at air temperature from 5 to 40° C.

The impacts and sharp shaking should be avoided.

It is forbidden to store the telescope together with acids, alkalies, materials which liberate moisture or chemically-active gases and vapours.

10. ACCEPTANCE CERTIFICATE

Telescope TAA-2 (TAA-2T), serial №, is found fit for service.

Date of manufacture and slushing _____

Signatures _____

Table of close stellar pairs for testing image quality of the telescope

Name of star	Coordinates		Magnitude, m	Visible distance, ang. s.	Constellations
	h, m	ang. degrees, ang. min.			
aPsc	1 ^h 59.4 ^m	+02°31'	4.3-5.3	1.9''	Pisces
gCet	2 ^h 40.7 ^m	+03°02'	3.4-4.4	2.8''	Cetus
xOri	5 ^h 38.2 ^m	-01°58'	2.0-4.2	2.5''	Orion
aGem	7 ^h 31.4 ^m	+32°00'	2.0-2.8	1.8''	Gemini
eHyd	8 ^h 44.1 ^m	-06°36'	3.5-6.9	2.9''	Hydra
sUma	9 ^h 06.0 ^m	+67°20'	4.9-8.2	2.7''	Ursa Major
38Lyn	9 ^h 15.8 ^m	+37°07'	4.9-6.0	2.8''	Lynx
xUma	11 ^h 15.6 ^m	+31°49'	4.4-4.8	2.9''	Ursa Major
xBoo	14 ^h 38.8 ^m	+13°56'	4.6-4.6	1.2''	Bootes
eBoo	14 ^h 42.8 ^m	+27°17'	2.7-5.1	3.0''	Bootes
mDra	17 ^h 04.3 ^m	+54°32'	5.8-5.8	2.2''	Draco
tOph	18 ^h 00.4 ^m	-08°11'	5.4-6.0	2.0''	Ophiucus
70 Oph	18 ^h 02.9 ^m	+02°31'	4.0-6.0	2.4''	Ophiucus
eLyr	18 ^h 42.7 ^m	+39°37'	5.1-6.2	2.7''	Lyra
eLyr	18 ^h 42.7 ^m	+39°37'	5.1-5.4	2.2''	Lyra
dCyg	19 ^h 43.4 ^m	+45°00'	3.0-6.5	2.2''	Cygnus
mCyg	21 ^h 41.9 ^m	+28°30'	4.7-6.1	1.8''	Cygnus
xAqr	22 ^h 26.3 ^m	-00°17'	4.4-4.6	1.8''	Aquarius